

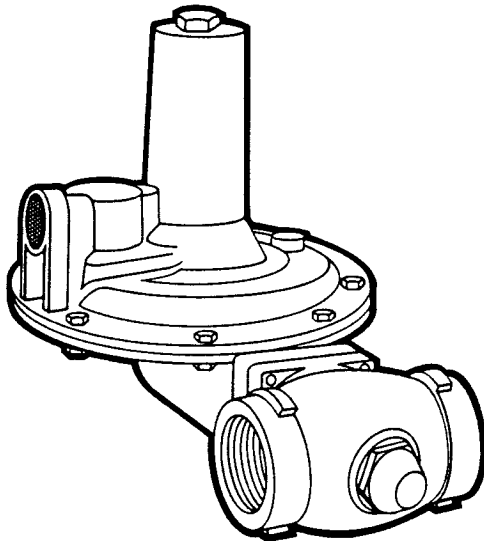

The Measure of the Future

243 Service Regulator With Low Pressure Cut-Off (LPCO)



243-8-4 (Low Pressure Cut-Off Only)

243-8-6 (Low Pressure Cut-Off
with Internal Relief Valve)

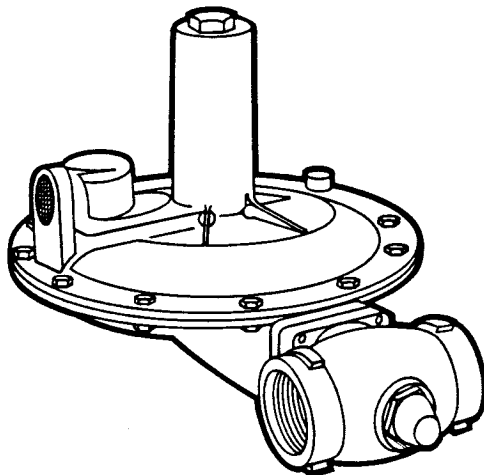

243-12-4 (Low Pressure Cut-Off Only)

243-12-16 (Low Pressure Cut-Off
with Internal Relief Valve)

Introduction

The **low pressure cut-off (LPCO)** is used to automatically shut off the gas when inlet pressure is no longer large enough for the required flow. It is an optional-extra safety device that is built into the 243 as an integral part of this regulator.

During normal operation the 243 provides its usual accurate control over the pressure of the delivered gas. However, if a line break or something else causes the regulator to open excessively as it attempts to handle the flow demand, the cut-off closes and shuts off the gas. This helps prevent a hazardous condition developing on the service side of the regulator.

As an added protection, the low pressure cut-off does not reset itself if inlet pressure happens to return to normal. Instead, it must be manually reset, thus helping to prevent a pressure malfunction from passing unnoticed.

Internal construction and capacities are given on pages 3 and 4. Note that these regulators are also available with an internal relief valve (IRV). References to the term *standard* indicate non-IRV configurations.

Cut-off data is given in the curves on page 5. These show the relationship between inlet pressure and flow for the various orifice sizes. Bodies are cast iron (ASTM A126- Class B). Diaphragm cases are die-cast aluminum alloy.

243-8-4 (Low pressure cut-off only)

243-8-6 (Low pressure cut-off plus internal relief valve)

Pipe Sizes: 1¼", 1½" and 2" screwed NPT
2" Flanged ANSI 125

Nominal Diaphragm Diameter: 8"

243-12-4 (Low pressure cut-off only)

243-12-6 (Low pressure cut-off plus internal relief valve)

Pipe Sizes: 1½" and 2" screwed NPT
2" Flanged ANSI 125

Nominal Diaphragm Diameter: 12"

MAXIMUM INLET PRESSURE

Model	Pipe Size	Orifice Size & Valve Angle		
		1" - 30°	¾" - 10°	½" - 10°
243-12-4 and 243-12-6	2"	25 psi	40 psi	75 psi
	1½"	25 psi	40 psi	60 psi
243-8-4 and 243-8-6	1½" & 2"	25 psi	25 psi	60 psi
	1¼"	—	15 psi	40 psi

Features and Dimensions
Model 243-8-4

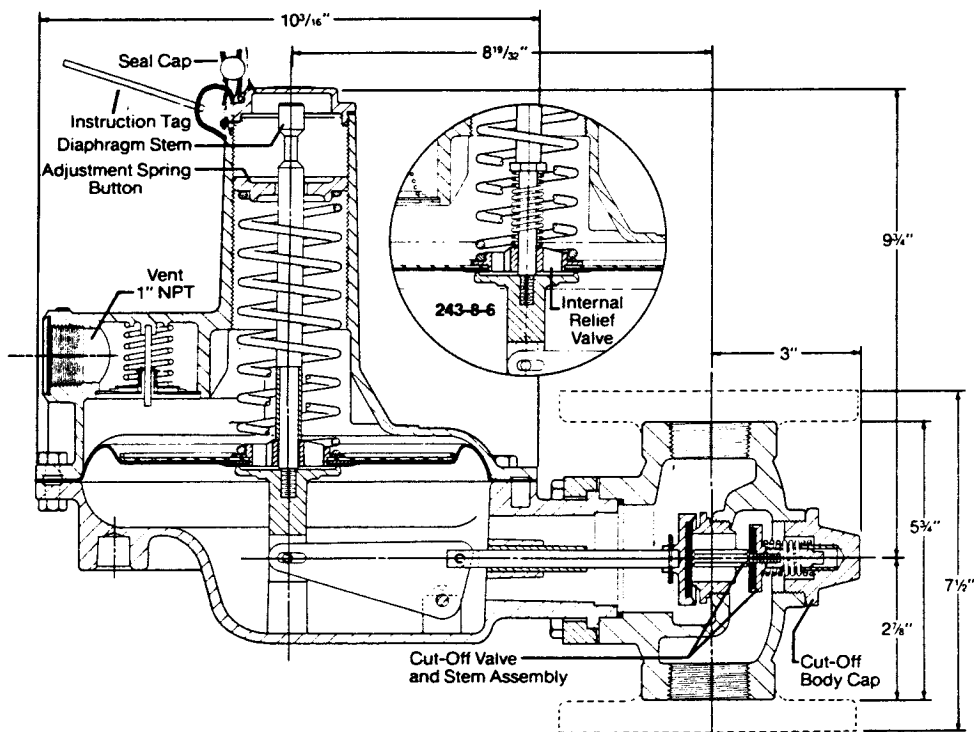

Model 243-12-6

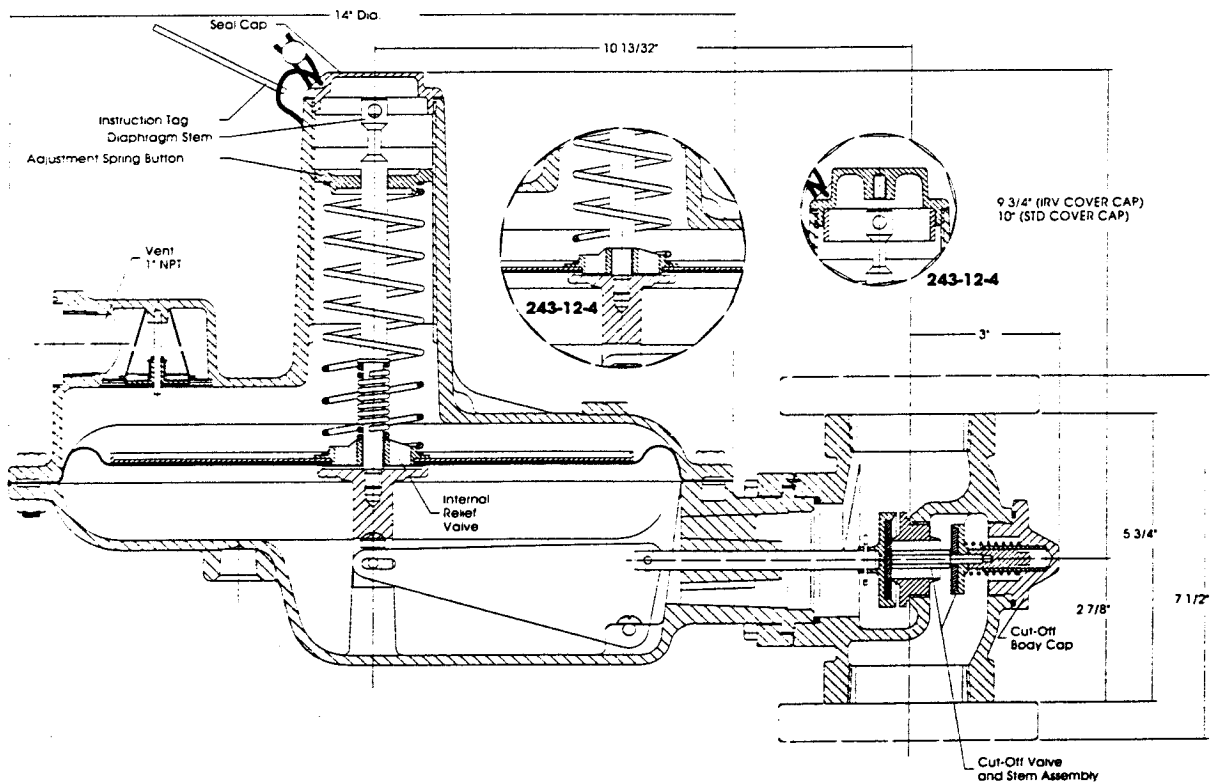



The Measure of the Future

CAPACITY in SCFH of Natural Gas†
1½" Model 243-8-4 and 1½" Model 243-8-6

OUTLET PRESSURE	INLET PRESSURE psi	Orifice Size & Valve Angle		
		1"	¾"	½"
		30°	10°	10°
6" w.c. (1" w.c. droop)	2	2700	1700	—
	5	4400	2900	1300
	10	6200	4300	2000
Red-Black Spring 5" to 8" w.c. 143-82-021-00	15	7800*	5400	2600
	25	—	7300*	3800
	40	—	—	5400
7" w.c. (1" w.c. droop)	2	2500	1400	—
	5	4100	2400	1300
	10	6100	4100	2000
Blue-Black Spring 6" to 12" w.c. 143-82-021-01	15	7800*	5200	2600
	25	—	7200*	3800
	40	—	—	5400
11" w.c. (2" w.c. droop)	2	2700	1650	—
	5	4400	2900	1300
	10	6200	4300	2000
Green-Black Spring 8" to 18" w.c. 143-82-021-02	15	7800*	5400	2600
	25	—	7300*	3800
	40	—	—	5400
18" w.c. (3" w.c. droop)	2	2200	1500	—
	5	4200	2800	1300
	10	6200	4300	2000
Green Spring 16" to 30" w.c. 143-16-021-05	15	7800*	5500	2600
	25	—	7500*	3800
	40	—	—	5400
1.0 psi (3.0" w.c. droop)	2	2200	1500	—
	5	4250	2800	1300
	10	6275	4350	2000
Green Spring 16" to 30" w.c. 143-16-021-05	15	7900*	5550	2600
	25	—	7600*	3800
	40	—	—	5450
	60	—	—	7100*

CAPACITY in SCFH of Natural Gas†
1¼" Model 243-8-4 and 1¼" Model 243-8-6

OUTLET PRESSURE	INLET PRESSURE psi	Orifice Size & Valve Angle	
		¾"	½"
		10°	10°
6" w.c. (1" w.c. droop)	2	1300	—
	5	1400	1250
	10	2400	1800
Red-Black Spring 5" to 8" w.c. 143-82-021-00	15	2800	2200
	25	—	2600
	40	—	3500
7" w.c. (1" w.c. droop)	2	1200	—
	5	1800	1100
	10	2300	1700
Blue-Black Spring 6" to 12" w.c. 143-82-021-01	15	2700	2200
	25	—	2600
	40	—	3500
11" w.c. (2" w.c. droop)	2	1350	—
	5	2100	1300
	10	2800	2000
Green-Black Spring 8" to 18" w.c. 143-82-021-02	15	3300	2500
	25	—	3200
	40	—	4000
18" w.c. (3" w.c. droop)	2	1350	—
	5	2200	1300
	10	2900	2000
Green Spring 16" to 30" w.c. 143-16-021-05	15	3400	2500
	25	—	3200
	40	—	4000
1.0 psi (3.0" w.c. droop)	2	1350	—
	5	2200	1300
	10	2900	2000
Green Spring 16" to 30" w.c. 143-16-021-05	15	3400	2500
	25	—	3200
	40	—	4050

†0.6 specific gravity, 14.65 psia and 60°F.

*At the inlet pressure and orifice size shown for each asterisked capacity, regulator should not be adjusted for a pressure lower than the indicated outlet pressure (bold face).



The Measure of the Future

CAPACITY in SCFH of Natural Gas†
2" Model 243-12-4 and 2" Model 243-12-6

OUTLET PRESSURE	INLET PRESSURE psi	Orifice Size & Valve Angle		
		1"	¾"	½"
		30°	10°	10°
6" w.c. (1" w.c. droop)	2	3600	2300	—
	5	5200	3400	1800
	10	7800	4400	2500
Red Spring 4" to 7" w.c. 143-16-021-03	15	10000	5700	3100
	25	13000*	8000	4000
	40	—	11000*	5500
	60	—	—	7300
	75	—	—	8700*
7" w.c. (1" w.c. droop)	2	3500	2100	—
	5	5200	3100	1500
	10	7800	4400	2100
Blue Spring 6" to 9½" w.c. 143-16-021-04	15	10000	5700	3000
	25	13000*	8000	4000
	40	—	11000*	5400
	60	—	—	7000
	75	—	—	8500*
11" w.c. (2" w.c. droop)	2	3500	2300	—
	5	5200	3200	1700
	10	7700	4400	2100
Green Spring 8" to 16" w.c. 143-16-021-05	15	10000	5700	3000
	25	13000*	8000*	4000
	40	—	11000*	5400
	60	—	—	7100
	75	—	—	8000*
18" w.c. (3" w.c. droop)	2	3300	2200	—
	5	5100	3300	1700
	10	7700	4400	2300
Orange Spring 16" to 30" w.c. 143-16-021-06	15	9800	5700	3000
	25	13000*	8000*	4000
	40	—	11000*	5500
	60	—	—	7300
	75	—	—	8700*
1.0 psi (3.0" w.c. droop)	2	3300	2200	—
	5	5150	3300	1700
	10	7800	4450	2300
Orange Spring 16" to 30" w.c. 143-16-021-06	15	9900	5750	3000
	25	13150*	8100	4050
	40	—	11100*	5050
	60	—	—	7400
	75	—	—	8750*

CAPACITY in SCFH of Natural Gas†
1½" Model 243-12-4 and 1½" Model 243-12-6

OUTLET PRESSURE	INLET PRESSURE psi	Orifice Size & Valve Angle		
		1"	¾"	½"
		30°	10°	10°
6" w.c. (1" w.c. droop)	2	3200	1800	—
	5	4600	3000	1400
	10	6400	4300	2100
Red Spring 4" to 7" w.c. 143-16-021-03	15	8000	5600	3000
	25	11000*	7700	4000
	40	—	10000*	5400
	60	—	—	7000
7" w.c. (1" w.c. droop)	2	3000	1800	—
	5	4500	3000	1400
	10	6200	4300	2100
Blue Spring 6" to 9½" w.c. 143-16-021-04	15	7600	5600	3000
	25	11000*	7600	4000
	40	—	10000*	5400
	60	—	—	7000
11" w.c. (2" w.c. droop)	2	3200	1700	—
	5	4600	3000	1400
	10	6400	4300	2100
Green Spring 8" to 16" w.c. 143-16-021-05	15	8000	5600	3000
	25	11000*	7700	4000
	40	—	10000*	5400
	60	—	—	7000
18" w.c. (3" w.c. droop)	2	2800	1600	—
	5	4500	3000	1400
	10	6300	4300	2100
Orange Spring 16" to 30" w.c. 143-16-021-06	15	7800	5600	3000
	25	11000*	7700	4000
	40	—	10000*	5400
	60	—	—	7000
1.0 psi (3.0" w.c. droop)	2	2800	1600	—
	5	4550	3000	1400
	10	6400	4350	2100
Orange Spring 16" to 30" w.c. 143-16-021-06	15	7900	5650	3000
	25	11100*	7800	4050
	40	—	10100*	5450
	60	—	—	7100*

†0.6 specific gravity, 14.65 psia and 60°F.

*At the inlet pressure and orifice size shown for each asterisked capacity, regulator should not be adjusted for a pressure lower than the indicated outlet pressure (bold face).

LPCO Operation Curves

These curves show the relationship between inlet pressure, flow and cut-off. At a given flow, cut-off occurs when inlet pressure drops below the indicated value. Conversely, at a given inlet pressure, cut-off occurs when flow exceeds the indicated amount.

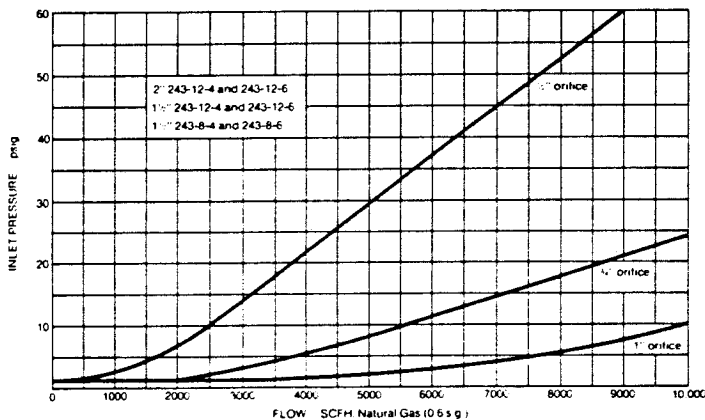
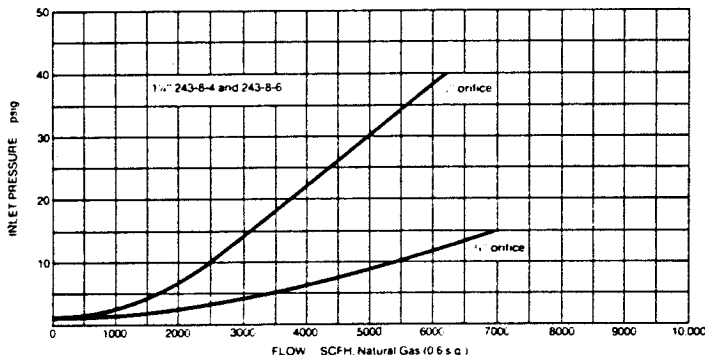

Periodic Inspection

Regulators are pressure control devices with numerous moving parts subject to wear that is dependent upon particular operating conditions. To assure continuous satisfactory operation, a periodic inspection schedule must be adhered to with the frequency of inspection determined by the severity of service and applicable laws and regulations.

Note: The use of an internal or external relief valve is recommended for installations subjected to no flow for extended periods of time, such as pilotless ignition systems. A travel stop stem is located in the 243-12-1 and 243-12-4 to provide overpressurization protection to internal components during overpressurization lockup.

Installation and Start-Up

- 1 In general, follow the procedures given in bulletin RM-1306-1 "Regulator Installation and Maintenance" for the 243.
- 2 The LPCO must be manually opened to put the regulator into operation (in an uninstalled regulator the LPCO is normally in the closed position).

To do this, remove the seal cap and pull upwards on the diaphragm stem. Hold in the upward position until it stays in this position by itself.

- 3 After the LPCO is in operation, final set point adjustment can be made with the adjustment spring button.

Servicing

- 1 In general, follow the servicing procedures given in the RM 1306-1 "Regulator Installation and Maintenance" for the 243.
- 2 Remove the cut-off body cap for access to the cut-off valve and stem assembly. Make certain all parts are reassembled in their correct order.
- 3 For cut-off parts, refer to RP 1306, the parts list for the 243.

Maximum Emergency Pressures

The maximum pressure the regulator inlet may be subject to under abnormal conditions without causing damage to the regulator is the maximum inlet pressure (from the table on Page 1) plus 10 psi.

The maximum pressure the diaphragm may be subject to without causing damage to the internal parts of the regulator is:

243-12-4Set-point +3 psi

243-12-6	}	Set-point +5 psi
243-8-4		
243-8-6		

If any of the above pressure limits are exceeded, the regulator must be taken out of service and inspected. Damaged or otherwise unsatisfactory parts must be repaired or replaced.

The maximum pressure that can be safely contained by the diaphragm case is:

243-12-4 and 243-12-615 psi
 243-8-4 and 243-8-615 psi

(safely contained means no leakage as well as no bursting).

Before using any of the above data, make sure this entire section is clearly understood.