

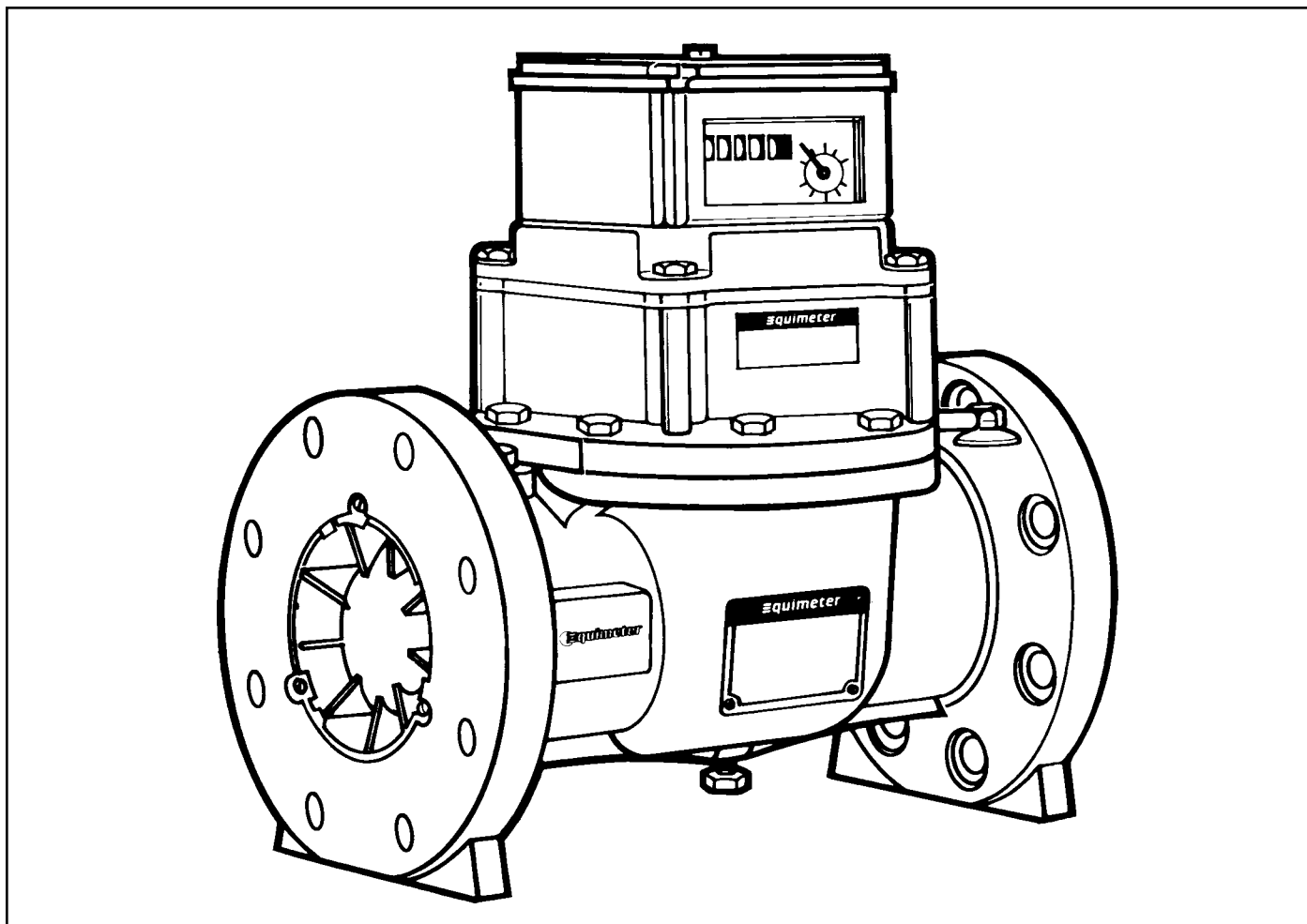

# Mark-II and Mark-II-E Turbo-Meters

with Slot Sensor Pulser  
on Follower Magnet Assembly  
or with Blade Tip Sensor (BTS)



## Slot Sensor Description\*

The Slot Sensor Pulser provides a high frequency electrical pulse signal which is directly proportional to the MK-II Turbo-Meter's mechanical output. Easily retrofitted to existing MK-II and PBT Turbo-Meters or factory installed in new meters. The pulser signals can be used to actuate a wide variety of remotely located electronic volume totalization or rate of flow devices.

Tables 1 through 10 detail data for pulses per unit of volume and pulse output frequency for each size of MK-II and MK-II-E Turbo-Meter.

The signal is generated from a slotted chopper disc mounted on the meter's follower magnet assembly. When the meter is operating, this disc rotates in the slot of an inductive proximity sensor which detects the presence or absence of metal.

Wiring from the sensor exits the meter's top-plate casting through either a 1/2"-14 NPT standard conduit fitting or a plug-in connector. To preserve the integrity of the intrinsically safe electrical system, wiring **must** be connected to either the specified safety barrier or the specified intrinsically safe transistor output module. Both of these accessory devices must be located in a safe (i.e. non-hazardous) area in accordance with Diagrams 1, 2, and 3. Note that Diagram 1 is applicable when remote instruments manufactured by Equimeter are used.

Connection Diagram 2 or 3 must be followed when connecting non-Equimeter instrumentation.

## Slot Sensor Retrofit Capability

Equimeter's MK-II Turbo-Meters have had the top-plate castings drilled and tapped as a production standard since mid-1975. Additionally, MK-II Turbo-Meters built prior to mid-1975 with saturable core pulse generators factory installed have the top-plate castings drilled and tapped. Slot Sensor Retrofit kits can be field installed on any MK-II Turbo-Meters with drilled and tapped top-plate castings. 4" MK-II Turbo-Meters with gear drive intermediate gear trains produced prior to June 1972, must be upgraded to dog drive to accept the slot sensor pulser.

As will be noted in the Retrofit Kit installation instructions which follow, the components involved are installed in a non-pressurized area above the meter top-plate. Therefore, meter blowdown is not necessary while making a Retrofit kit installation.

Equimeter's High Pressure Production Turbo-Meters (PTB models) have the same follower magnet assemblies and top-plate castings as their MK-II Turbo-Meter counterparts. Therefore, previous statements pertaining to MK-II Turbo-Meter retrofit capability are also applicable to PTB models.

\*Blade Tip Sensors description and instructions begin on page 17.

## Retrofit Kits—Components

Slot sensor retrofit kits with conduit connectors all have the same components except for the 8" T-60 and 12" T-140 Turbo-Meters. These larger sizes require extenders for the conduit connector to clear the outside diameter of the meter top-plate.

Slot sensor retrofit kits ordered with plug-in connectors all have the same components, regardless of meter size or working pressure.

## Retrofit Kit Part Numbers

Turbo-Meter Size and Model	Conduit Connector	Plug-in Connector
2" T-4.5, 3" T-8.8, 4" T-18, T-27 or PTB-18	006-24-633-00	006-24-633-01
6" T-30, T-35, T-57, or PTB-30	006-24-633-00	006-24-633-01
8" T-60, T-90, or PTB-60	006-26-633-00	006-24-633-01
12" T-140 or T-230	006-31-633-00	006-24-633-01

NOTE: When ordering MK-II Turbo-Meter Slot Sensor Pulsar Retrofit Kits, be sure to also order either a safety barrier or transistor output control amplifier module as appropriate. Refer to Diagrams 1, 2, and 3.

## New Meters—Factory Installation

New MK-II, MK-II-E, or PTB Turbo-Meters can, of course, be ordered with the Slot Sensor Pulsar factory installed. Just specify this option when new meter orders are placed and, again, be sure to also specify either the safety barrier or transistor output module, see Diagrams 1, 2, and 3 on pages 14, 15, and 16.

### CAUTION

***To preserve the integrity of the intrinsically safe electrical system, wiring must conform to the specifications detailed in Diagrams 1, 2, and 3 for Slot Sensor; 4 and 5 for BTS.***

## Retrofit Kit Components

Item*	Part Number	Part Description
1	006-24-313-22	Follower magnet /17 slot chopper disc assembly for all sizes of MK-II Turbo-Meters
2	006-24-319-03	Slot sensor/bracket assembly
2C	006-24-319-04	Slot sensor without bracket and bracket mounting hardware (for replacing slot sensor switch only)
3	903373	#8-32 x 1/2" long machine screw*
4	950371	#8-Flat washer*
4A	950078	#4 Ext. Lockwasher
5A	006-22-222-02	1/2"-14 NPT conduit/wire adapter for all sizes of Turbo-Meters
5B	006-22-250-00	Plug-in connector, male (meter) end, for all sizes of Turbo-Meters
6A	006-22-122-05	Flange adapter for conduit connector
6B	006-22-122-06	Flange adapter for plug-in connector
7A	006-26-122-93	1/2" NPT conduit extender, (used for 8" T-60 meters only)
7B	006-31-122-03	1/2" NPT conduit extender, (used for 12" T-140 meters only)
8	800646	Shrink Tubing (Two 1/2" long pieces required)
21	903055	#8-32 x 1/4" lg. stainless steel Rd. Hd. Screw (4 required)
22	006-32-131-01	Cap and chain (for plug-in connector)
23	950124	Plug-in connector, female (outboard) end

\* Refer to call-out number on drawings Figures 1, 2, 3, and 4 for conduit assembly, and Figures 5, 6, 7, and 8 for plug-in assembly.

**Follower Magnet and Bearing Assembly  
 With Chopper Disc (X Section, Side View)**

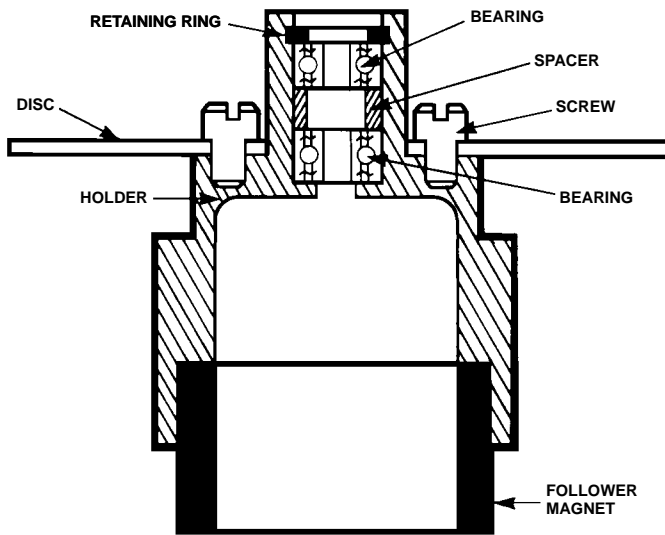

**Follower Magnet and Bearing Assembly  
 With 17 Slot Chopper Disc (Top View)**

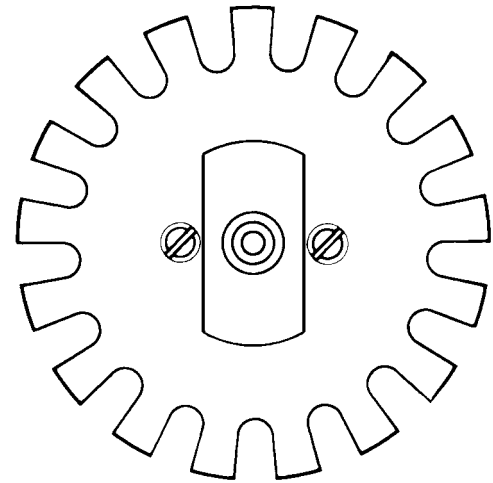

**Drive System**

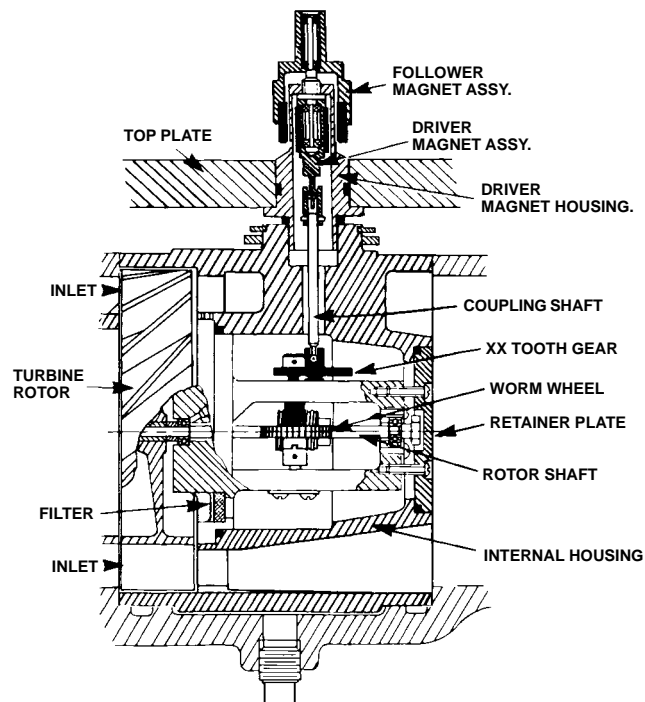

## Slot Sensor Retrofit Kit Installation Instructions

(Both Conduit and Plug-In Connector)

### Disassembly (Refer to Figure 1 or 5)

- 1 Remove instrument and/or index box cover (8 and 9).
- 2 Remove index plate and index (10,11,12, and 13).
- 3 Remove intermediate gear train (14 and 15).  
NOTE: Retain all the above items for reassembly later.
- 4 Remove follower magnet and discard (16).
- 5 Remove probe cover plate or existing pulser probe (18, 19, and 24).  
NOTE: Save three cap screws (24) and three lock washers (19) for later reassembly.

### Reassembly (Refer to Figure 1 or 5)

- 1 Place the new follower magnet/chopper assembly (1) onto the magnet well post.
- 2 Reassemble intermediate gear train (15) in top plate (17). Use only two of the three retaining screws (14) in the two holes farthest from the probe mounting hole.

- 3 Insert mounting screw (3), flat washer (4), and lock-washer (4A) into sensor bracket (2).
- 4 Hold the sensor bracket by the thumb tab (2B) and place it down into the top plate (Figure 2 or 6).  
NOTE: While lowering the sensor bracket into place, rotate the switch and wires away from the chopper disc and gears. Then tighten screw (3) to hold the sensor bracket assembly in place.
- 5 **For Conduit Connector (Figures 1,2,3, and 4):**
  - a. For top plates with three hold probe connection drilling: assemble the flange adapter (6A) with the three lock washers (19) and cap screws (24). Then insert the short end of the wire of the 1/2" NPT conduit/wire adapter (5A) through the probe hole and screw the connection tight.
  - b. For top plates with 1/2" NPT tapped probe connection: insert the wire connector end of the 1/2" NPT conduit wire adapter (5A) through the probe hole and screw the connection tight (flange adapter (6A) is not required).
  - c. If installation is on 8" T-60 or 12" T-140 meter, screw the appropriate conduit extender (7A) or (7B) onto the wire adapter.

## Conduit Connector

⊙ Indicates A Retrofit Kit Component (page 2).

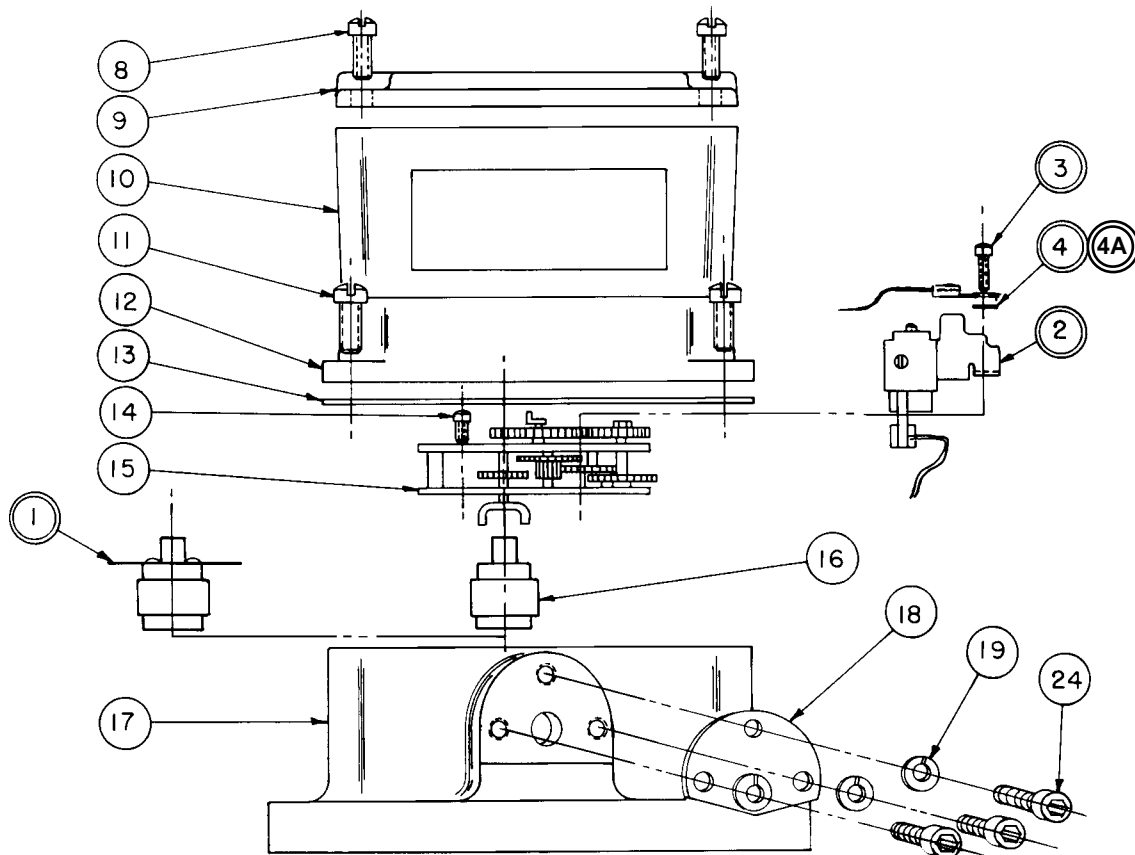

FIGURE 1

### For Plug-in Connector (Figures 5,6,7, and 8):

- a. Assemble wire adapter (6B) with three caps screws (24) and lockwashers (19).
- b. Insert the wires of the connector (5B) through the probe hole in the top plate casting.
- c. Assemble with (21) and (22) (orient connector key at top—12 o'clock position).

- 6 Slide a piece of shrink tubing (20) over each of the wires from the slot sensor (2C). Solder connect wires from slot sensor (2C) to wires from connector (5A) or (5B) (red to red, black to black). Slide shrink tubing (20) over each soldered joint and heat shrink tubing over joints. Route wires away from moving parts.

### Adjustment

Refer to Figures 3 and 4 for conduit connector, Figures 7 and 8 for plug-in connector.

- 1 Loosen screw (3)—this will allow the sensor assembly to pivot (2B) (Figure 3).
- 2 Loosen locking screw (2D) and adjust the vertical position of sensor switch by turning the adjustment screw (2E) to position the disc in the center of the opening in the slot sensor

(2C). Clockwise will raise the switch, counterclockwise will lower the switch.

- 3 Pivot the sensor assembly until the chopper disc extends into the switch slot approximately  $\frac{3}{16}$ ".

This can be accomplished by pivoting the sensor assembly until the chopper disc contacts the back of the switch slot, then back off the sensor assembly to provide approximately  $\frac{1}{16}$ " clearance (Figures 3 and 4 or 7 and 8).

- 4 Hold the sensor assembly in position while tightening the pivot locking screw (3).

- 5 Check vertical adjustment of switch for clearance by rotating the chopper disc a complete revolution. Make final adjustment with screw (2E) and lock in position by tightening screw (2D) (Figure 4 or 8).

NOTE: If possible, before reassembling the index plate and index and/or instrument, complete the wiring per Diagrams 1 and 2. Verify the adjustment of the sensor switch through the electrical operation.

NOTE: It is also recommended that the switch slot and chopper disc clearance be checked while the meter is running.

### Conduit Connector

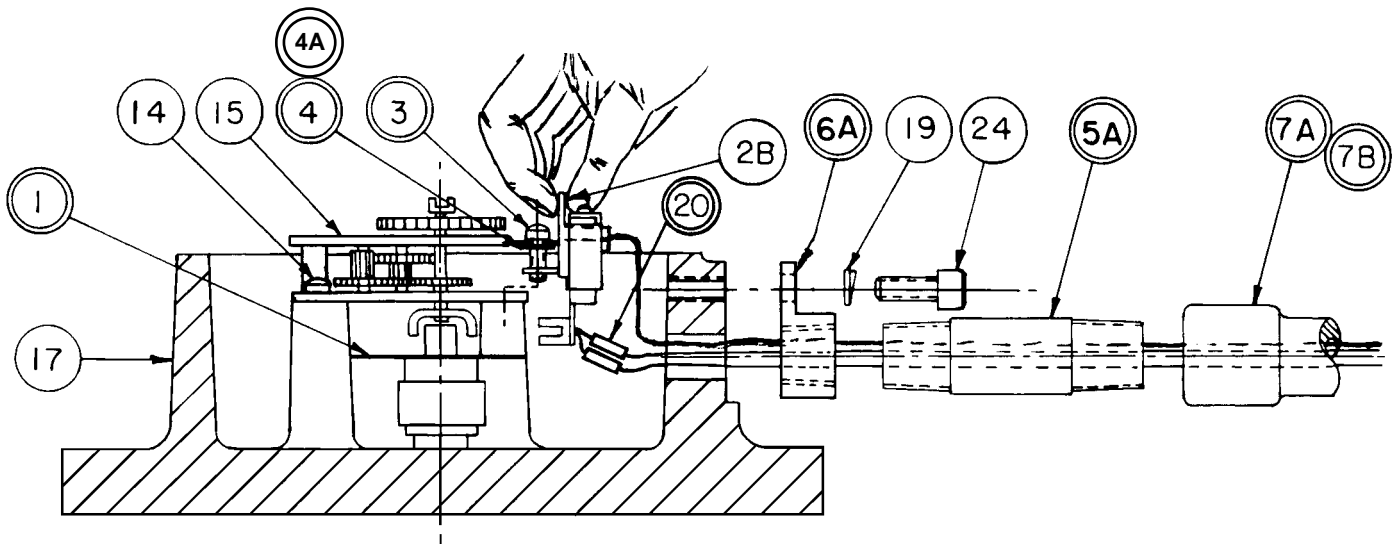

FIGURE 2

**Conduit Connector**

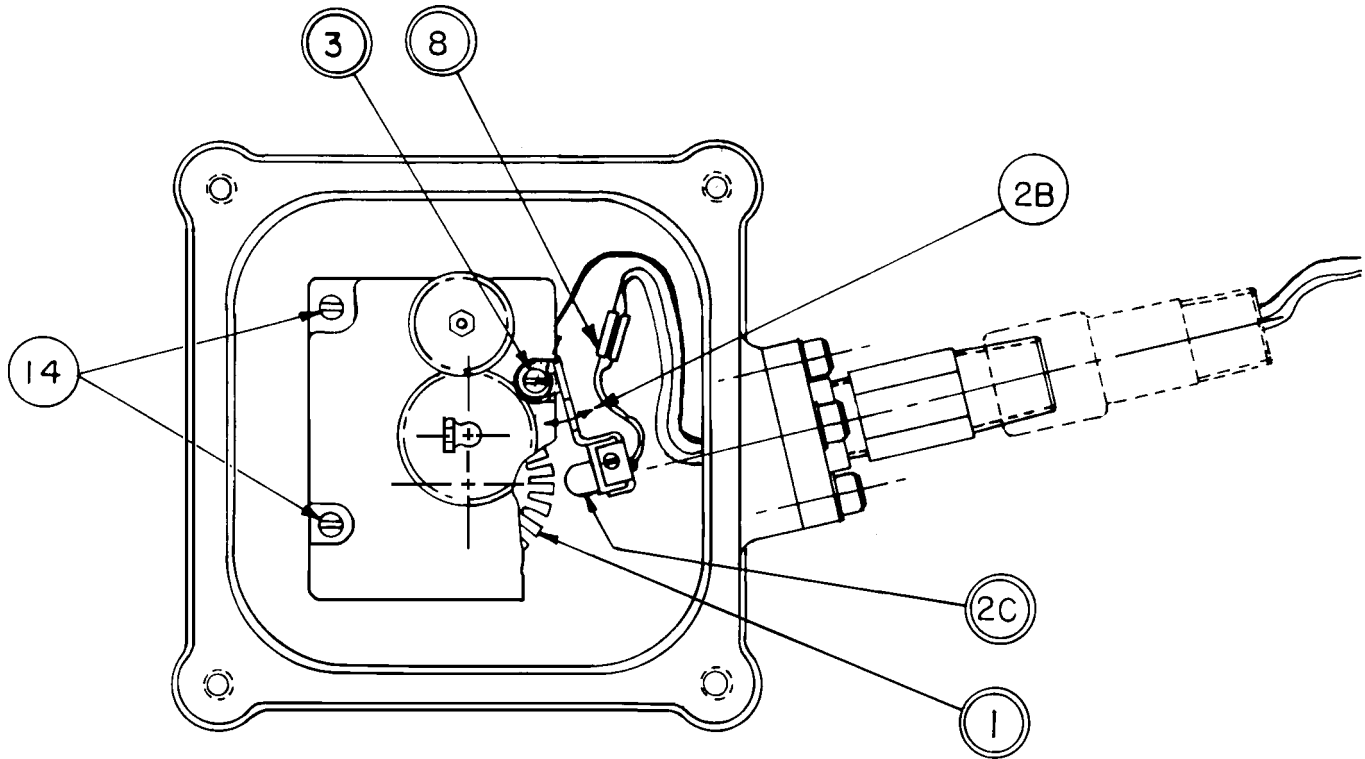

FIGURE 3

**Conduit Connector**

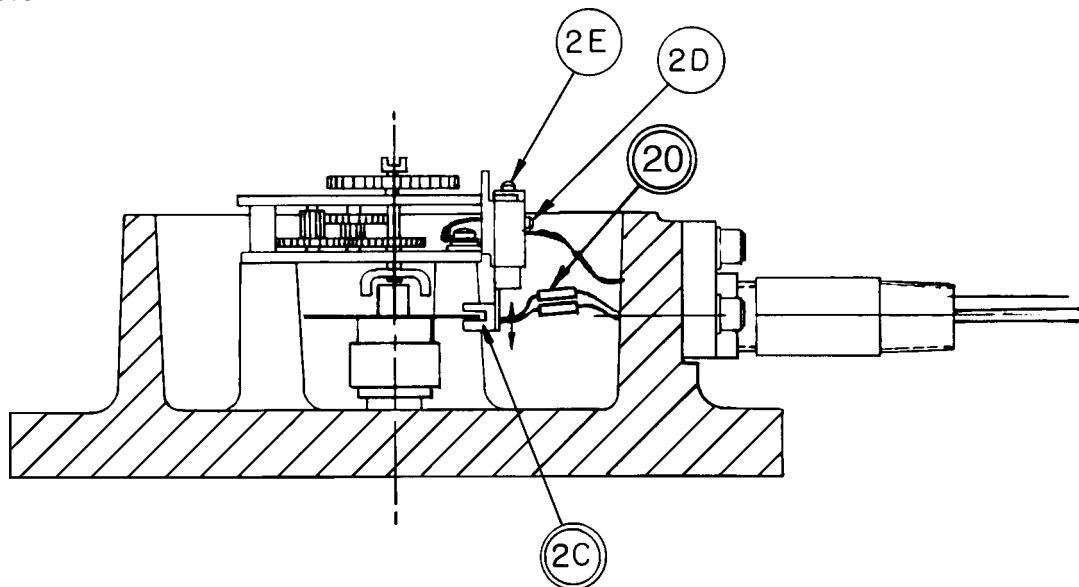

FIGURE 4

Plug-In Connector ○ Indicates A Retrofit Kit Component (page 2).

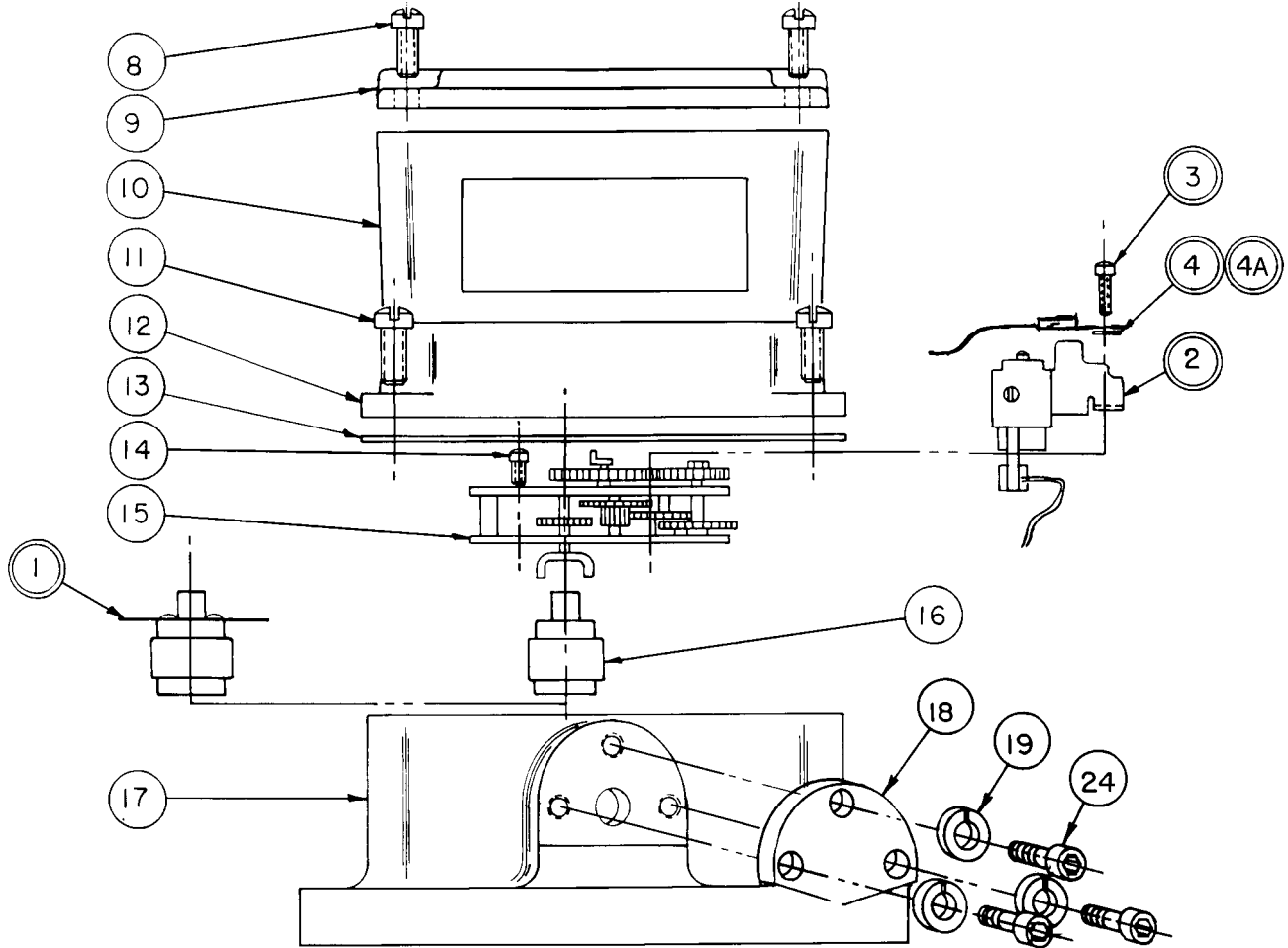

FIGURE 5

Plug-In Connector

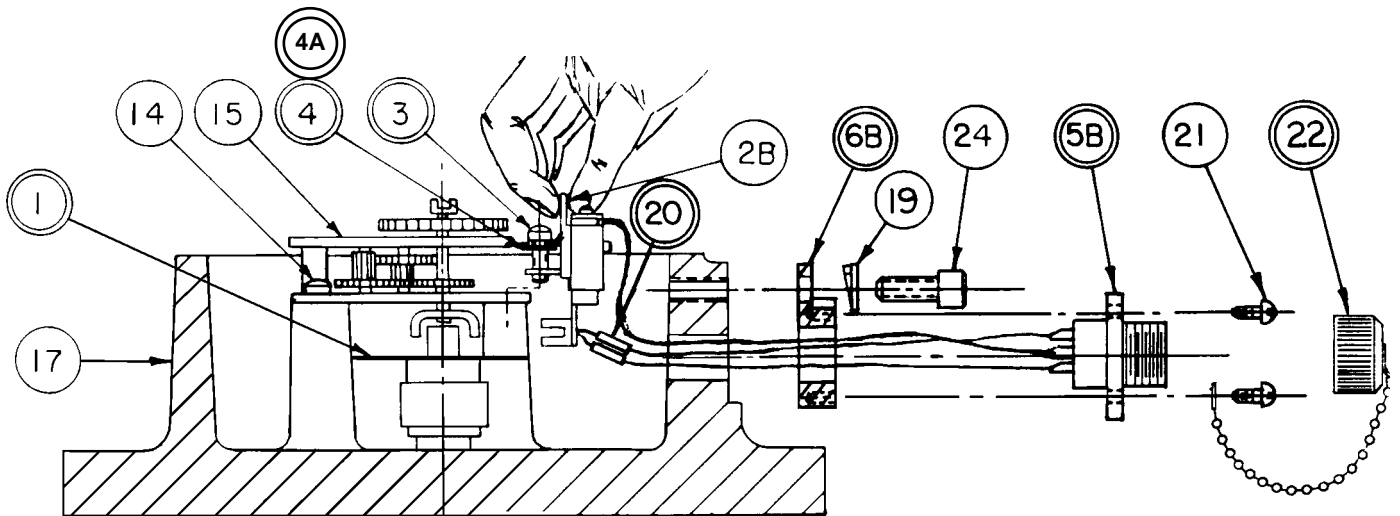

FIGURE 6

**Plug-In Connector**

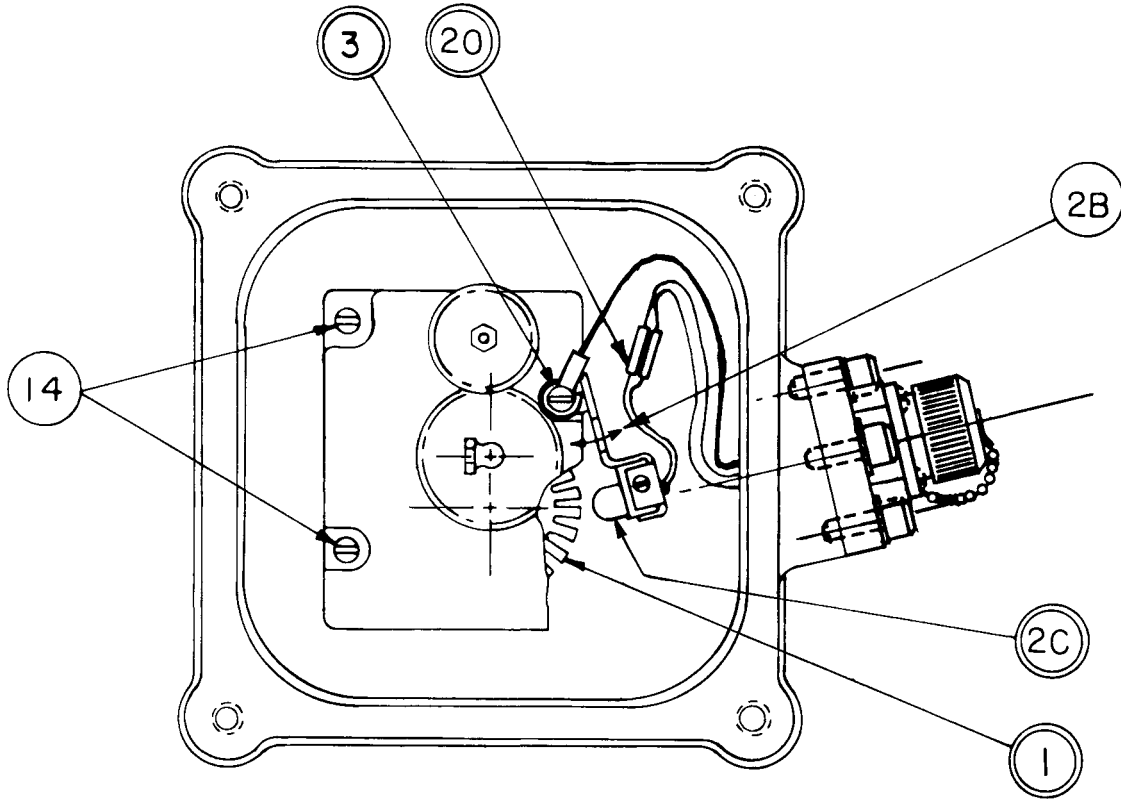

FIGURE 7

**Plug-In Connector**

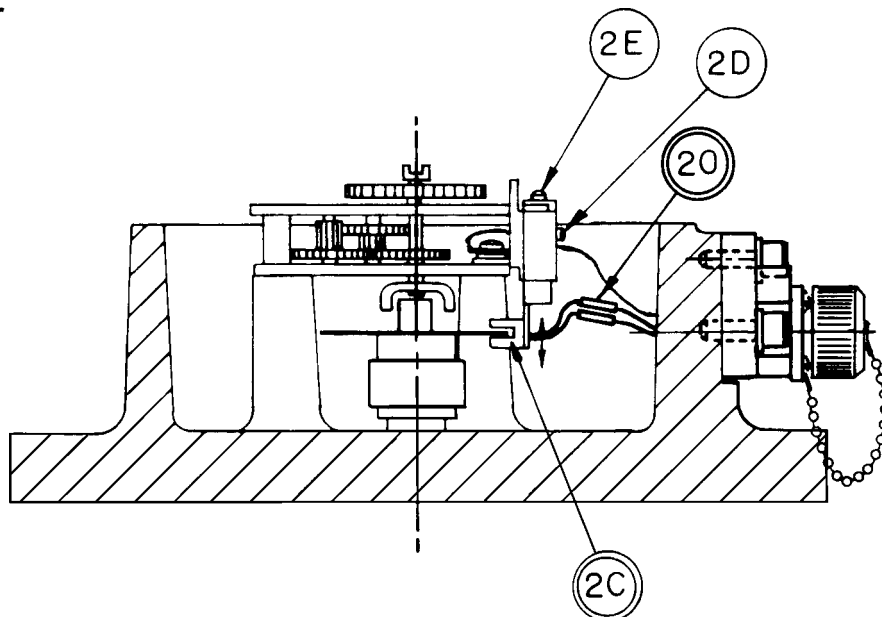

FIGURE 8

**2" T-4.5 and 3" T-8.8 MK-IIE Turbo-Meter/ With Slot Sensor Pulsar on Follower Magnet Assembly**

**T-4.5 Table 1 - Pulses Per Unit of Volume and Pulse Output Frequency Table**

			STANDARD CONSTRUCTION				SPECIAL CONSTRUCTION			
Chopper Disc			17 Slots		17 Slots		17 Slots		17 Slots	
Max. Capacity			4500 ACFH		127 m <sup>3</sup> /H		4500 ACFH		127 m <sup>3</sup> /H	
Mechanical Output			10 ft <sup>3</sup> /Rev.		0.1 m <sup>3</sup> /Rev.		1 ft <sup>3</sup> /Rev.		1 m <sup>3</sup> /Rev.	
Inter. Gear Ratio			122.0555 to 1**		43.10526 to 1**		12.1125 to 1		431.0526 to 1	
CHANGE GEARS			ENGLISH		METRIC		ENGLISH		METRIC	
LG	SM	RATIO	p/ft <sup>3</sup>	Hz	p/m <sup>3</sup>	Hz	p/ft <sup>3</sup>	Hz	p/m <sup>3</sup>	Hz
66-65T	55-54T	1.20370	249.762	312.202	8820.613	311.172	247.858	309.822	8820.613	311.172
66-64T	55-53T	1.20755	250.559	313.199	8848.778	312.165	248.649	310.811	8848.778	312.165
66-69T	55-57T	1.21053	251.177	313.972	8870.609	312.935	249.263	311.578	8870.609	312.935
66-63T	55-52T	1.21154	251.387	314.234	8878.026	313.197	249.471	311.839	8878.026	313.197
66-68T	55-56T	1.21429	251.957	314.947	8898.157	313.907	250.037	312.546	8898.157	313.907
66-67T*	55-55T	1.21818	252.766	315.957	8926.707	314.914	250.839	313.549	8926.707	314.914
66-66T	55-54T	1.22220	253.604	317.005	8956.315	315.959	251.671	314.589	8956.315	315.959
66-65T	55-53T	1.22642	254.474	318.093	8987.040	317.043	252.534	315.668	8987.040	317.043
69-64T	55-52T	1.23077	255.378	319.222	9018.947	318.168	253.431	316.788	9018.947	318.168
66-69T	55-56T	1.23214	255.663	319.578	9020.012	318.523	253.714	317.142	9029.012	318.523
66-68T	55-55T	1.23636	256.538	320.673	9059.942	319.615	254.583	318.228	9059.942	319.615

**T-8.8 Table 2 - Pulses Per Unit of Volume and Pulse Output Frequency Table**

			STANDARD CONSTRUCTION				SPECIAL CONSTRUCTION			
Chopper Disc			17 Slots		17 Slots		17 Slots		17 Slots	
Max. Capacity			8800 ACFH		250 m <sup>3</sup> /H		8800 ACFH		250 m <sup>3</sup> /H	
Mechanical Output			100 ft <sup>3</sup> /Rev.		1 m <sup>3</sup> /Rev.		10 ft <sup>3</sup> /Rev.		10 m <sup>3</sup> /Rev.	
Inter. Gear Ratio			122.0555 to 1**		43.10526 to 1**		12.1125 to 1		431.0526 to 1	
CHANGE GEARS			ENGLISH		METRIC		ENGLISH		METRIC	
LG	SM	RATIO	p/ft <sup>3</sup>	Hz	p/m <sup>3</sup>	Hz	p/ft <sup>3</sup>	Hz	p/m <sup>3</sup>	Hz
66-65T	55-56T	1.16071	24.084	58.872	850.559	59.067	23.901	58.424	850.559	59.067
66-64T	55-55T	1.16363	24.145	59.021	852.700	59.215	23.961	58.571	852.700	59.215
66-63T	55-54T	1.16667	24.208	59.174	854.921	59.370	24.023	58.723	854.921	59.370
66-68T	55-58T	1.17241	24.327	59.466	859.132	59.662	24.141	59.012	859.132	59.662
66-67T	55-57T	1.17544	24.390	59.619	861.349	59.816	24.204	59.165	861.349	59.816
66-66T*	55-56T	1.17857	24.455	59.778	863.645	59.975	24.268	59.322	863.645	59.975
66-65T	55-55T	1.18482	24.522	59.943	866.024	60.141	24.335	59.486	866.024	60.141
66-64T	55-54T	1.18519	24.592	60.114	868.491	60.312	24.404	59.655	868.419	60.312
66-63T	55-53T	1.18868	24.664	60.291	871.052	60.490	24.476	59.831	871.052	60.490
66-69T	55-58T	1.18965	24.685	60.340	871.767	60.539	24.496	59.880	871.767	60.539
66-68T	55-57T	1.19298	24.754	60.509	874.205	60.709	24.565	60.048	874.205	60.709

\* Base Change Gear Set

\*\* Brass or Plastic Intermediate Gear Train

NOTE: All current construction MK-II and MK-IIE Turbo-Meters have plastic intermediate gear trains.

**EXAMPLE:** (with T-8.8 Base Change Gear Set)

$$p/ft^3 = \frac{(\text{intermediate gear ratio}) \times (\text{number of teeth on large change gear}) \times (\text{number of chopper disc slots})}{(\text{mechanical output}) \times (\text{number of teeth on small change gear})}$$

$$p/ft^3 = \frac{122.0555 \times 66 \times 17}{100 \times 56} = \frac{136,946.2710}{5600} = 24.455 \text{ pulses/cubic foot}$$

$$Hz = \frac{p/ft^3 \times \text{maximum capacity}}{3600} = \frac{24.455 \times 8800}{3600} = 59.778 \text{ pulses per second at the maximum flow rate}$$

**4" T-18 and T-27 MK-II Turbo-Meter/ With Slot Sensor Pulser on Follower Magnet Assembly**

**T-18 Table 3 - Pulses Per Unit of Volume and Pulse Output Frequency Table**

			STANDARD CONSTRUCTION						SPECIAL CONSTRUCTION			
Chopper Disc			17 Slots		17 Slots		17 Slots		17 Slots		17 Slots	
Max. Capacity			18,000 ACFH		510 m <sup>3</sup> /H		510 m <sup>3</sup> /H		18,000 ACFH		510 m <sup>3</sup> /H	
Mechanical Output			100 ft <sup>3</sup> /Rev.		10 m <sup>3</sup> /Rev.		10 m <sup>3</sup> /Rev.		10 ft <sup>3</sup> /Rev.		1 m <sup>3</sup> /Rev.	
Inter. Gear Ratio			122.0555 to 1**		431.0526(Brass)		430.1073(Plast.)		12.1125 to 1**		43.10526 to 1**	
CHANGE GEARS			ENGLISH		METRIC		METRIC		ENGLISH		METRIC	
LG	SM	RATIO	p/ft <sup>3</sup>	Hz	p/m <sup>3</sup>	Hz	p/m <sup>3</sup>	Hz	p/ft <sup>3</sup>	Hz	p/m <sup>3</sup>	Hz
74-73T	47-48T	1.52083	31.556	157.782	1114.451	157.881	1112.007	157.534	31.316	156.579	1114.451	157.881
74-75T	47-49T	1.53061	31.759	158.797	1121.617	158.896	1119.157	158.547	31.517	157.586	1121.617	158.896
74-74T	47-48T	1.54167	31.989	159.944	1129.717	160.043	1127.240	159.692	31.745	158.724	1129.717	160.043
74-71T	47-46T	1.54348	32.026	160.132	1131.045	160.231	1128.564	159.880	31.782	158.911	1131.045	160.231
74-76T	47-49T	1.55102	32.183	160.914	1136.571	161.014	1134.079	160.661	31.937	159.687	1136.571	161.014
74-73T*	47-47T	1.55319	32.228	161.139	1138.162	161.240	1135.666	160.886	31.982	159.911	1138.162	161.240
74-75T	47-48T	1.56250	32.421	162.105	1144.984	162.206	1142.473	161.850	32.174	160.869	1144.984	162.206
74-77T	47-49T	1.57143	32.606	163.031	1151.526	163.133	1149.001	162.775	32.358	161.788	1151.526	163.133
74-74T	47-47T	1.57447	32.669	163.347	1153.754	163.448	1151.223	163.090	32.420	162.101	1153.754	163.448
74-76T	47-48T	1.58333	32.853	164.266	1160.250	164.369	1157.706	164.008	32.603	163.014	1160.250	164.369
74-73T	47-46T	1.58696	32.928	164.642	1162.905	164.745	1160.355	164.384	32.677	163.387	1162.905	164.745

**T-27 Table 4 - Pulses Per Unit of Volume and Pulse Output Frequency Table**

			STANDARD CONSTRUCTION						SPECIAL CONSTRUCTION			
Chopper Disc			17 Slots		17 Slots		17 Slots		17 Slots		17 Slots	
Max. Capacity			27,000 ACFH		765 m <sup>3</sup> /H		765 m <sup>3</sup> /H		27,000 ACFH		765 m <sup>3</sup> /H	
Mechanical Output			100 ft <sup>3</sup> /Rev.		10 m <sup>3</sup> /Rev.		10 m <sup>3</sup> /Rev.		10 ft <sup>3</sup> /Rev.		1 m <sup>3</sup> /Rev.	
Inter. Gear Ratio			122.0555 to 1**		431.0526(Brass)		430.1073(Plast.)		12.1125 to 1**		43.10526 to 1**	
CHANGE GEARS			ENGLISH		METRIC		METRIC		ENGLISH		METRIC	
LG	SM	RATIO	p/ft <sup>3</sup>	Hz	p/m <sup>3</sup>	Hz	p/m <sup>3</sup>	Hz	p/ft <sup>3</sup>	Hz	p/m <sup>3</sup>	Hz
71-69T	50-49T	1.40816	29.219	219.139	1031.887	219.276	1029.624	218.795	28.996	217.469	1031.887	219.276
71-72T	50-51T	1.41176	29.293	219.700	1034.526	219.837	1032.258	219.355	29.070	218.025	1034.526	219.837
71-68T	50-48T	1.41667	29.395	220.463	1038.118	220.600	1035.842	220.116	29.171	218.782	1038.118	220.600
71-71T	50-50T	1.42000	29.464	220.981	1040.561	221.119	1038.279	220.634	29.240	219.297	1040.561	221.119
71-74T	50-52T	1.42308	29.528	221.460	1042.816	221.598	1040.529	221.112	29.303	219.772	1042.816	221.598
71-70T*	50-49T	1.42857	29.642	222.315	1046.842	222.454	1044.546	221.966	29.416	220.621	1046.842	222.454
71-73T	50-51T	1.43137	29.700	222.751	1048.895	222.890	1046.594	222.401	29.474	221.053	1048.895	222.890
71-69T	50-48T	1.43750	29.827	223.705	1053.385	223.844	1051.075	223.353	29.600	221.999	1053.385	223.844
71-72T	50-50T	1.44000	29.879	224.094	1055.217	224.234	1052.903	223.742	29.651	222.386	1055.217	224.234
71-71T	50-49T	1.44898	30.066	225.491	1061.797	225.632	1059.468	225.137	29.836	223.772	1061.797	225.632
71-74T	50-51T	1.45098	30.107	225.803	1063.263	225.943	1060.931	225.448	29.878	224.081	1063.263	225.943

\* Base Change Gear Set

\*\* Brass or Plastic Intermediate Gear Train

NOTE: All current construction MK-II Turbo-Meters have plastic intermediate gear trains.

**EXAMPLE:** (with T-18 Base Change Gear Set)

$$p/ft^3 = \frac{(\text{intermediate gear ratio}) \times (\text{number of teeth on large change gear}) \times (\text{number of chopper disc slots})}{(\text{mechanical output}) \times (\text{number of teeth on small change gear})}$$

$$p/ft^3 = \frac{122.0555 \times 73 \times 17}{100 \times 47} = \frac{151,470.8755}{4700} = 32.2278 \text{ pulses/cubic foot}$$

$$Hz = \frac{p/ft^3 \times \text{maximum capacity}}{3600} = \frac{32.2278 \times 18,000}{3600} = 161.139 \text{ pulses per second at the maximum flow rate}$$

**6" T-35 and T-57 MK-II Turbo-Meter/ With Slot Sensor Pulser on Follower Magnet Assembly**

**T-35 Table 5 - Pulses Per Unit of Volume and Pulse Output Frequency Table**

			STANDARD CONSTRUCTION						SPECIAL CONSTRUCTION			
Chopper Disc			17 Slots		17 Slots		17 Slots		17 Slots		17 Slots	
Max. Capacity			35,000 ACFH		990 m <sup>3</sup> /H		990 m <sup>3</sup> /H		35,000 ACFH		990 m <sup>3</sup> /H	
Mechanical Output			100 ft <sup>3</sup> /Rev.		10 m <sup>3</sup> /Rev.		10 m <sup>3</sup> /Rev.		10 ft <sup>3</sup> /Rev.		1 m <sup>3</sup> /Rev.	
Inter. Gear Ratio			122.0555 to 1**		431.0526(Brass)		430.1073(Plast.)		12.1125 to 1**		43.10526 to 1**	
CHANGE GEARS			ENGLISH		METRIC		METRIC		ENGLISH		METRIC	
LG	SM	RATIO	p/ft <sup>3</sup>	Hz	p/m <sup>3</sup>	Hz	p/m <sup>3</sup>	Hz	p/ft <sup>3</sup>	Hz	p/m <sup>3</sup>	Hz
71-72T	50-51T	1.41176	29.293	284.796	1034.526	284.495	1032.258	283.871	29.070	282.625	1034.526	284.495
71-68T	50-48T	1.41667	29.395	285.785	1038.118	285.483	1035.842	284.856	29.171	283.606	1038.118	285.483
71-71T	50-50T	1.42000	29.464	286.457	1040.561	286.154	1038.279	285.527	29.240	284.274	1040.561	286.154
71-74T	50-52T	1.42308	29.528	287.078	1042.816	286.774	1040.529	286.145	29.303	284.890	1042.816	286.774
71-70T	50-49T	1.42857	29.642	288.187	1046.842	287.882	1044.546	287.250	29.416	285.990	1046.842	287.882
71-73T*	50-51T	1.43137	29.700	288.752	1048.895	288.446	1046.594	287.813	29.474	286.550	1048.895	288.446
71-69T	50-48T	1.43750	29.827	289.988	1053.385	289.681	1051.075	289.046	29.600	287.777	1053.385	289.681
71-72T	50-50T	1.44000	29.879	290.492	1055.217	290.185	1052.903	289.548	29.651	288.278	1055.217	290.185
71-71T	50-49T	1.44898	30.066	292.304	1061.797	291.994	1059.468	291.354	29.836	290.075	1061.797	291.994
71-74T	50-51T	1.45098	30.107	292.707	1063.263	292.397	1060.931	291.756	29.878	290.476	1063.263	292.397
71-70T	50-48T	1.45833	30.260	294.190	1068.651	293.879	1066.308	293.235	30.029	291.948	1068.651	293.879

**T-57 Table 6 - Pulses Per Unit of Volume and Pulse Output Frequency Table**

			STANDARD CONSTRUCTION						SPECIAL CONSTRUCTION			
Chopper Disc			17 Slots		17 Slots		17 Slots		17 Slots		17 Slots	
Max. Capacity			57,000 ACFH		1615 m <sup>3</sup> /H		1615 m <sup>3</sup> /H		57,000 ACFH		1615 m <sup>3</sup> /H	
Mechanical Output			100 ft <sup>3</sup> /Rev.		10 m <sup>3</sup> /Rev.		10 m <sup>3</sup> /Rev.		10 ft <sup>3</sup> /Rev.		1 m <sup>3</sup> /Rev.	
Inter. Gear Ratio			122.0555 to 1**		431.0526(Brass)		430.1073(Plast.)		12.1125 to 1**		43.10526 to 1**	
CHANGE GEARS			ENGLISH		METRIC		METRIC		ENGLISH		METRIC	
LG	SM	RATIO	p/ft <sup>3</sup>	Hz	p/m <sup>3</sup>	Hz	p/m <sup>3</sup>	Hz	p/ft <sup>3</sup>	Hz	p/m <sup>3</sup>	Hz
71-71T	50-51T	1.39215	28.886	457.369	1020.158	457.654	1017.921	456.650	28.666	453.882	1020.158	457.654
71-70T	50-50T	1.40000	29.049	459.946	1025.905	460.232	1023.655	459.223	28.828	456.439	1025.905	460.232
71-73T	50-52T	1.40385	29.129	461.209	1028.724	461.497	1026.468	460.485	28.907	457.693	1028.724	461.497
71-69T	50-49T	1.40816	29.219	462.628	1031.887	462.916	1029.624	461.901	28.996	459.101	1031.887	462.916
71-72T	50-51T	1.41176	29.293	463.811	1034.526	464.100	1032.258	463.082	29.070	460.275	1034.526	464.100
71-68T*	50-48T	1.41667	29.395	465.421	1038.118	465.711	1035.842	464.690	29.171	461.873	1038.118	465.711
71-71T	50-50T	1.42000	29.464	466.516	1040.561	466.807	1038.279	465.784	29.240	462.960	1040.561	466.807
71-74T	50-52T	1.42308	29.528	467.527	1042.816	467.819	1040.529	466.793	29.303	463.963	1042.816	467.819
71-70T	50-49T	1.42857	29.642	469.332	1046.842	469.625	1044.546	468.595	29.416	465.754	1046.842	469.625
71-73T	50-51T	1.43137	29.700	470.253	1048.895	470.546	1046.594	469.514	29.474	466.668	1048.895	470.546
71-69T	50-48T	1.43750	29.827	472.266	1053.385	472.560	1051.075	471.524	29.600	468.665	1053.385	472.560

\* Base Change Gear Set

\*\* Brass or Plastic Intermediate Gear Train

NOTE: All current construction MK-II Turbo-Meters have plastic intermediate gear trains.

**EXAMPLE:** (with T-35 Base Change Gear Set)

$$p/ft^3 = \frac{(\text{intermediate gear ratio}) \times (\text{number of teeth on large change gear}) \times (\text{number of chopper disc slots})}{(\text{mechanical output}) \times (\text{number of teeth on small change gear})}$$

$$p/ft^3 = \frac{122.0555 \times 73 \times 17}{100 \times 51} = \frac{151,470.8755}{5100} = 29.7002 \text{ pulses/cubic foot}$$

$$Hz = \frac{p/ft^3 \times \text{maximum capacity}}{3600} = \frac{29.7002 \times 35,000}{3600} = 288.752 \text{ pulses per second at the maximum flow rate}$$

### 8" T-60 and T-90 MK-II Turbo-Meter/ With Slot Sensor Pulsar on Follower Magnet Assembly

**T-60 Table 7 - Pulses Per Unit of Volume and Pulse Output Frequency Table**

			STANDARD CONSTRUCTION				SPECIAL CONSTRUCTION					
Chopper Disc			17 Slots		17 Slots		17 Slots		17 Slots		17 Slots	
Max. Capacity			60,000 ACFH		1699 m <sup>3</sup> /H		60,000 ACFH		1699 m <sup>3</sup> /H		1699 m <sup>3</sup> /H	
Mechanical Output			1000 ft <sup>3</sup> /Rev.		10 m <sup>3</sup> /Rev.		100 ft <sup>3</sup> /Rev.		100 m <sup>3</sup> /Rev.		100 m <sup>3</sup> /Rev.	
Inter. Gear Ratio			122.0555 to 1**		43.10526 to 1**		12.1125 to 1**		431.0526 (Brass)		430.1073 (Plastic)	
CHANGE GEARS			ENGLISH		METRIC		ENGLISH		METRIC		METRIC	
LG	SM	RATIO	p/ft <sup>3</sup>	Hz	p/m <sup>3</sup>	Hz	p/ft <sup>3</sup>	Hz	p/m <sup>3</sup>	Hz	p/m <sup>3</sup>	Hz
74-77T	47-49T	1.57143	3.261	54.344	115.153	54.346	3.236	53.929	115.153	54.346	114.900	54.226
74-74T	47-47T	1.57447	3.267	54.449	115.375	54.451	3.242	54.034	115.375	54.451	115.122	54.331
74-76T	47-48T	1.58333	3.285	54.755	116.025	54.757	3.260	54.338	116.025	54.757	115.771	54.637
74-73T	47-46T	1.58696	3.293	54.881	116.291	54.883	3.268	54.462	116.291	54.883	116.035	54.762
74-75T	47-47T	1.59574	3.311	55.185	116.934	55.187	3.286	54.764	116.934	55.187	116.678	55.066
74-77T*	47-48T	1.60417	3.329	55.476	117.552	55.478	3.303	55.053	117.552	55.478	117.294	55.356
74-74T	47-46T	1.60870	3.338	55.633	117.884	55.634	3.313	55.208	117.884	55.634	117.625	55.512
74-76T	47-47T	1.61702	3.355	55.920	118.494	55.922	3.330	55.494	118.494	55.922	118.234	55.800
74-73T	47-45T	1.62222	3.366	56.100	118.875	56.102	3.340	55.673	118.875	56.102	118.614	55.979
74-75T	47-46T	1.63043	3.383	56.384	119.477	56.386	3.357	55.954	119.477	56.386	119.215	56.263
74-77T	47-47T	1.63830	3.399	56.656	120.053	56.658	3.373	56.224	120.053	56.658	119.789	56.534

**T-90 Table 8 - Pulses Per Unit of Volume and Pulse Output Frequency Table**

			STANDARD CONSTRUCTION				SPECIAL CONSTRUCTION					
Chopper Disc			17 Slots		17 Slots		17 Slots		17 Slots		17 Slots	
Max. Capacity			90,000 ACFH		2549 m <sup>3</sup> /H		90,000 ACFH		2549 m <sup>3</sup> /H		2549 m <sup>3</sup> /H	
Mechanical Output			1000 ft <sup>3</sup> /Rev.		10 m <sup>3</sup> /Rev.		100 ft <sup>3</sup> /Rev.		100 m <sup>3</sup> /Rev.		100 m <sup>3</sup> /Rev.	
Inter. Gear Ratio			122.0555 to 1**		43.10526 to 1**		12.1125 to 1**		431.0526 (Brass)		430.1073 (Plastic)	
CHANGE GEARS			ENGLISH		METRIC		ENGLISH		METRIC		METRIC	
LG	SM	RATIO	p/ft <sup>3</sup>	Hz	p/m <sup>3</sup>	Hz	p/ft <sup>3</sup>	Hz	p/m <sup>3</sup>	Hz	p/m <sup>3</sup>	Hz
71-70T	50-51T	1.37254	2.848	71.199	100.579	71.215	2.826	70.656	100.579	71.215	100.358	71.059
71-69T	50-50T	1.38000	2.863	71.586	101.125	71.602	2.845	71.040	101.125	71.602	100.903	71.445
71-72T	50-52T	1.38461	2.873	71.825	101.463	71.842	2.851	71.277	101.463	71.842	101.241	71.684
71-68T	50-49T	1.38775	2.880	71.988	101.693	72.004	2.858	71.439	101.693	72.004	101.470	71.847
71-71T	50-51T	1.39215	2.889	72.216	102.016	72.233	2.867	71.666	102.016	72.233	101.792	72.074
71-70T*	50-50T	1.40000	2.905	72.623	102.591	72.640	2.883	72.069	102.591	72.640	102.366	72.480
71-73T	50-52T	1.40385	2.913	72.823	102.872	72.839	2.891	72.267	102.872	72.839	102.647	72.680
71-69T	50-49T	1.40816	2.922	73.046	103.189	73.063	2.900	72.490	103.189	73.063	102.962	72.903
71-72T	50-51T	1.41176	2.929	73.233	103.453	73.250	2.907	72.675	103.453	73.250	103.226	73.090
71-68T	50-48T	1.41667	2.940	73.488	103.812	73.505	2.917	72.927	103.812	73.505	103.584	73.343
71-71T	50-50T	1.42000	2.946	73.660	104.056	73.677	2.924	73.099	104.056	73.677	103.828	73.516

\* Base Change Gear Set

\*\* Brass or Plastic Intermediate Gear Train

NOTE: All current construction MK-II Turbo-Meters have plastic intermediate gear trains.

**EXAMPLE:** (with T-60 Base Change Gear Set)

$$p/ft^3 = \frac{(\text{intermediate gear ratio}) \times (\text{number of teeth on large change gear}) \times (\text{number of chopper disc slots})}{(\text{mechanical output}) \times (\text{number of teeth on small change gear})}$$

$$p/ft^3 = \frac{122.0555 \times 77 \times 17}{1000 \times 48} = \frac{159,770.6495}{48,000} = 3.3286 \text{ pulses/cubic foot}$$

$$Hz = \frac{p/ft^3 \times \text{maximum capacity}}{3600} = \frac{3.3286 \times 60,000}{3600} = 55.476 \text{ pulses per second at the maximum flow rate}$$

**12" T-140 and T-230 MK-II Turbo-Meter/ With Slot Sensor Pulser on Follower Magnet Assembly**

**T-140 Table 9 - Pulses Per Unit of Volume and Pulse Output Frequency Table**

			STANDARD CONSTRUCTION				SPECIAL CONSTRUCTION					
Chopper Disc			17 Slots		17 Slots		17 Slots		17 Slots		17 Slots	
Max. Capacity			140,000 ACFH		3964 m <sup>3</sup> /H		140,000 ACFH		3964 m <sup>3</sup> /H		3964 m <sup>3</sup> /H	
Mechanical Output			1000 ft <sup>3</sup> /Rev.		10 m <sup>3</sup> /Rev.		100 ft <sup>3</sup> /Rev.		100 m <sup>3</sup> /Rev.		100 m <sup>3</sup> /Rev.	
Inter. Gear Ratio			122.0555 to 1**		43.10526 to 1**		12.1125 to 1**		431.0526 (Brass)		430.1073 (Plastic)	
CHANGE GEARS			ENGLISH		METRIC		ENGLISH		METRIC		METRIC	
LG	SM	RATIO	p/ft <sup>3</sup>	Hz	p/m <sup>3</sup>	Hz	p/ft <sup>3</sup>	Hz	p/m <sup>3</sup>	Hz	p/m <sup>3</sup>	Hz
66-68T	55-53T	1.28302	2.662	103.530	94.018	103.525	2.642	102.740	94.018	103.525	93.812	103.298
66-67T	55-52T	1.28846	2.673	103.969	94.417	103.964	2.653	103.176	94.417	103.964	94.210	103.736
69-70T	52-54T	1.29630	2.690	104.601	94.991	104.596	2.669	103.804	94.991	104.596	94.783	104.367
66-69T	55-53T	1.30189	2.701	105.052	95.401	105.047	2.681	104.251	95.401	105.047	95.192	104.817
66-68T	55-52T	1.30769	2.713	105.521	95.826	105.515	2.693	104.716	95.826	105.515	95.616	105.284
69-67T*	52-51T	1.31373	2.726	106.007	96.268	106.002	2.705	105.199	96.268	106.002	96.057	105.770
69-70T	52-53T	1.32075	2.740	106.575	96.784	106.569	2.720	105.762	96.784	106.569	96.571	106.336
66-69T	55-52T	1.32692	2.753	107.072	97.236	107.067	2.732	106.256	97.236	107.067	97.022	106.832
71-68T	50-51T	1.33333	2.767	107.590	97.705	107.584	2.746	106.769	97.705	107.584	97.491	107.348
69-67T	52-50T	1.34000	2.780	108.128	98.194	108.122	2.759	107.303	98.194	108.122	97.978	107.885
71-70T	50-51T	1.37255	2.848	110.754	100.579	110.749	2.826	109.910	100.579	110.749	100.358	110.506

**T-230 Table 10 - Pulses Per Unit of Volume and Pulse Output Frequency Table**

			STANDARD CONSTRUCTION				SPECIAL CONSTRUCTION					
Chopper Disc			17 Slots		17 Slots		17 Slots		17 Slots		17 Slots	
Max. Capacity			230,000 ACFH		6513 m <sup>3</sup> /H		230,000 ACFH		6513 m <sup>3</sup> /H		6513 m <sup>3</sup> /H	
Mechanical Output			1000 ft <sup>3</sup> /Rev.		10 m <sup>3</sup> /Rev.		100 ft <sup>3</sup> /Rev.		100 m <sup>3</sup> /Rev.		100 m <sup>3</sup> /Rev.	
Inter. Gear Ratio			122.0555 to 1**		43.10526 to 1**		12.1125 to 1**		431.0526 (Brass)		430.1073 (Plastic)	
CHANGE GEARS			ENGLISH		METRIC		ENGLISH		METRIC		METRIC	
SM	LG	RATIO	p/ft <sup>3</sup>	Hz	p/m <sup>3</sup>	Hz	p/ft <sup>3</sup>	Hz	p/m <sup>3</sup>	Hz	p/m <sup>3</sup>	Hz
50-49T	71-69T	0.71014	1.474	94.141	52.039	94.147	1.462	93.423	52.039	94.147	51.925	93.940
50-51T	71-72T	0.70833	1.470	93.901	51.906	93.906	1.459	93.185	51.906	93.906	51.792	93.701
50-48T	71-68T	0.70588	1.465	93.576	51.726	93.582	1.454	92.863	51.726	93.582	51.613	93.376
50-50T	71-71T	0.70423	1.461	93.356	51.605	93.362	1.450	92.645	51.605	93.362	51.492	93.157
50-52T	71-74T	0.70270	1.458	93.154	51.493	93.160	1.447	92.444	51.493	93.160	51.380	92.956
50-49T*	71-70T	0.70000	1.452	92.796	51.295	92.802	1.441	92.089	51.295	92.802	51.183	92.598
50-51T	71-73T	0.69863	1.450	92.614	51.195	92.620	1.439	91.908	51.195	92.620	51.083	92.417
50-48T	71-69T	0.69565	1.443	92.220	50.977	92.225	1.432	91.517	50.977	92.225	50.865	92.023
50-50T	71-72T	0.69444	1.441	92.060	50.888	92.065	1.430	91.358	50.888	92.065	50.777	91.863
50-49T	71-71T	0.69014	1.432	91.489	50.573	91.495	1.421	90.792	50.573	91.495	50.462	91.294
50-51T	71-74T	0.68919	1.430	91.363	50.503	91.368	1.419	90.666	50.503	91.368	50.392	91.168

\* Base Change Gear Set

\*\* Brass or Plastic Intermediate Gear Train

NOTE: All current construction MK-II Turbo-Meters have plastic intermediate gear trains.

**EXAMPLE:** (with T-140 Base Change Gear Set)

$$p/ft^3 = \frac{(\text{intermediate gear ratio}) \times (\text{number of teeth on large change gear}) \times (\text{number of chopper disc slots})}{(\text{mechanical output}) \times (\text{number of teeth on small change gear})}$$

$$p/ft^3 = \frac{122.0555 \times 67 \times 17}{1000 \times 51} = \frac{139,021.2145}{51,000} = 2.7259 \text{ pulses/cubic foot}$$

$$Hz = \frac{p/ft^3 \times \text{maximum capacity}}{3600} = \frac{2.7259 \times 140,000}{3600} = 106.007 \text{ pulses per second at the maximum flow rate}$$

**Connection Diagram for MK-II Turbo-Meter  
With Slot Sensor Pulsar and MPB-II Flow Computer or ACT-Pak Instruments**

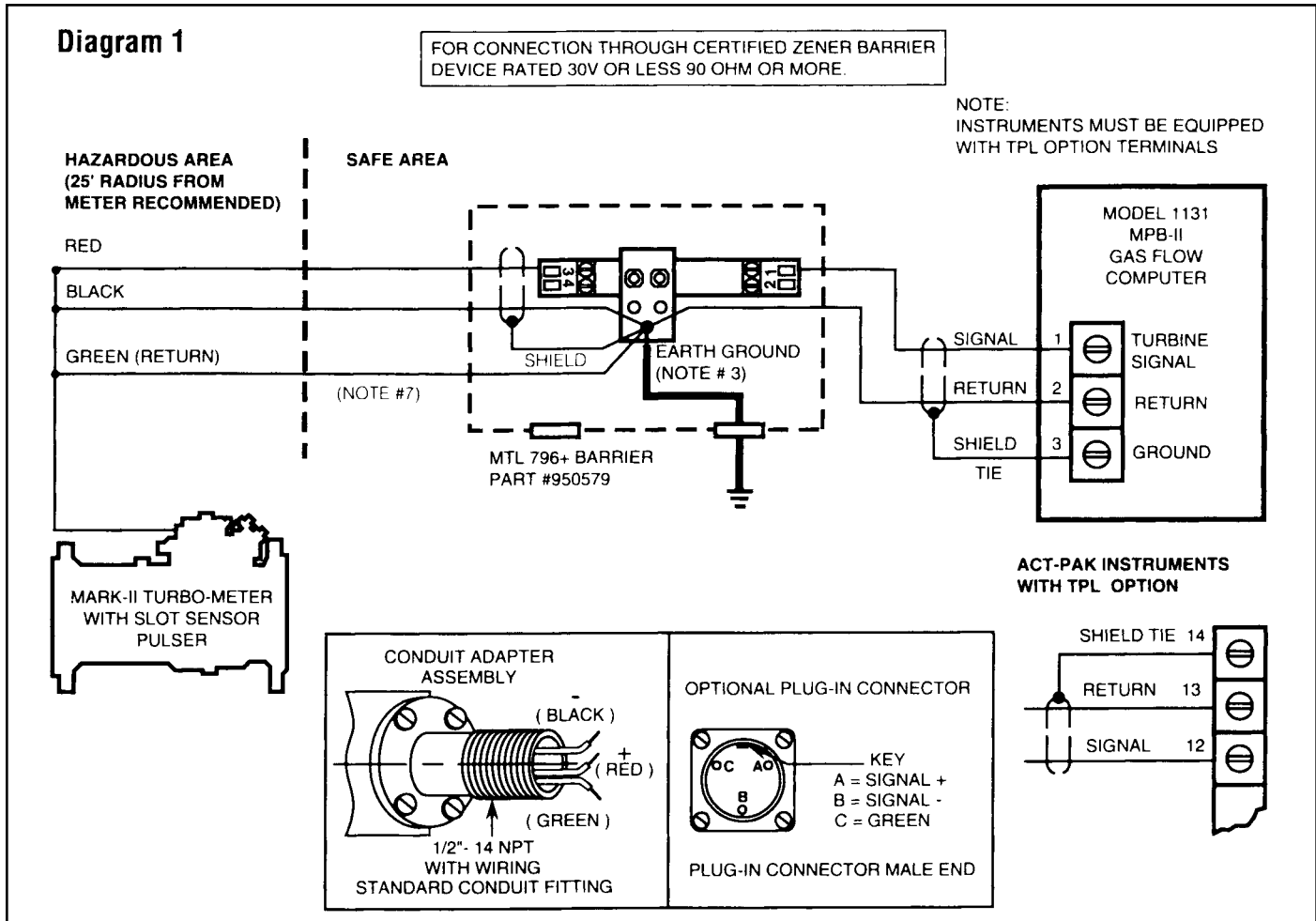

**Barrier Enclosure**

**MT-2 for One or Two Barriers— Part #950580**  
**MT-5 for up to Five Barriers Maximum— Part #950581**

Barrier must be installed according to manufacturer's instructions and must comply with applicable local codes in a manner approved by the authority having jurisdiction. Refer to installation instructions packaged with barrier.

- 1** All signal wires connecting the Slot Sensor to the shunt diode safety barriers must be run separately from all other wiring. This is necessary to comply with the intrinsic safety guidelines.
- 2** Use 2 conductor #18 twisted shielded cable, Belden 8760 or equivalent. For maximum protection, conduit is recommended.
- 3** Ground bus is connected to earth ground by an insulated #12 wire, or larger if required by local codes. Resistance to ground must be less than one ohm. Local codes may require redundant ground wires (two places).

- 4** Maximum cable length from meter to barrier must be less than 1,000 feet.
- 5** Wiring system shown is applicable for use with Equimeter MPB-II Flow Computer or Equimeter ACT-Pak instruments only. Do not use this diagram for systems incorporating instruments not made by Equimeter.
- 6** See wiring diagram on Equimeter ACT-Pak instruments for detail on terminal connections.
- 7** If meter is isolated, connect green ground wire to earth ground at safety barrier. If meter is not isolated, do not connect green wire to ground.

**NOTE**

**Refer to Diagrams 2 and 3  
on pages 15 and 16 when connecting to  
non-Equimeter instruments.**

**Connection Diagram for MK-II Turbo-Meter  
With Slot Sensor Pulsar for Non-Equimeter Instrumentation (120 VAC Supply)**

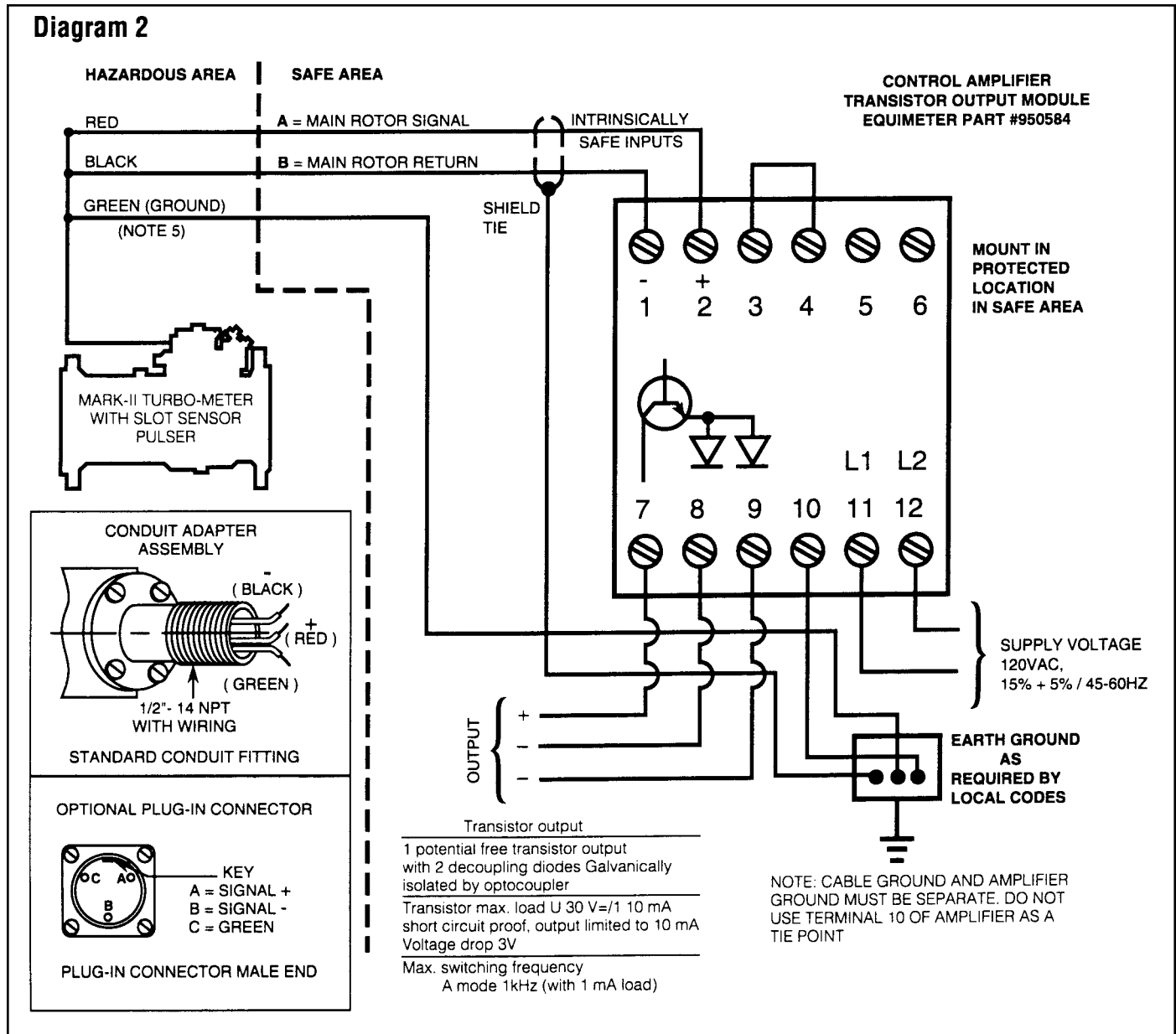

**Control Amplifier Enclosure  
MTL-UC2— Part #950583**

Control amplifier must be installed according to manufacturer's instructions, and must comply with applicable local codes in a manner approved by the authority having jurisdiction. Refer to installation instructions packaged with control amplifier.

- 1 All signal wires connecting the Slot Sensor to the control and amplifier must be run separately from all other wiring. This is necessary to comply with the intrinsic safety guidelines.

- 2 Use 2 conductor #18 twisted shielded cable, Belden 8760 or equivalent. For maximum protection, conduit is recommended.
- 3 Maximum cable length from meter to barrier must be less than 1,000 feet.
- 4 Module IS P.F. Control Amplifier WE77/EX1-OT or Equimeter Part #950584.
- 5 If meter is isolated, connect wire to earth ground. If meter is not isolated, do not connect green wire to ground.

**Connection Diagram for MK-II Turbo-Meter  
With Slot Sensor Pulsar for Non-Equimeter Instrumentation (24 VDC Supply)**

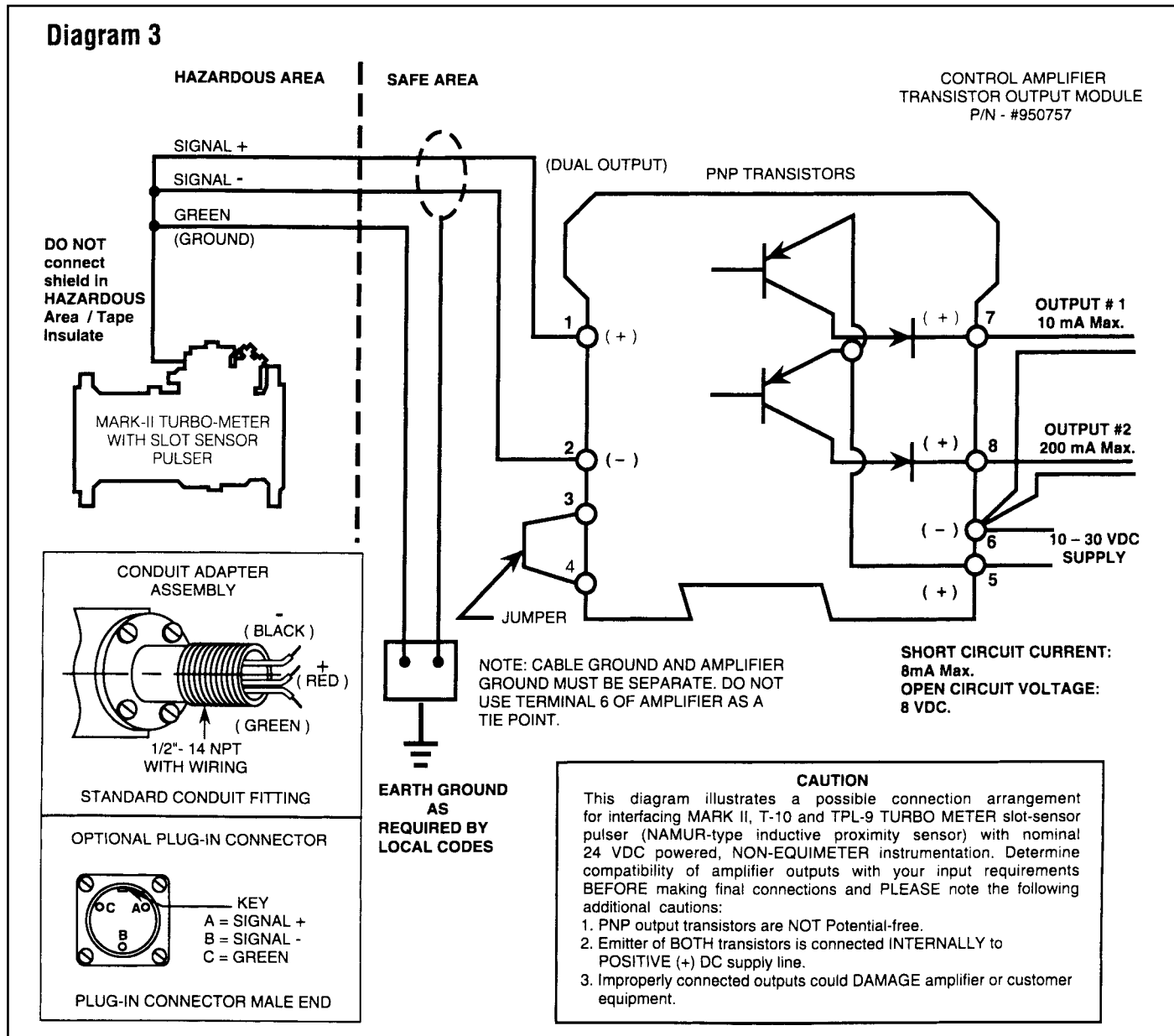

**Control Amplifier Enclosure  
MTL-UC2— Part #950583**

Control amplifier must be installed according to manufacturer's instructions, and must comply with applicable local codes in a manner approved by the authority having jurisdiction. Refer to installation instructions packaged with control amplifier.

- 1 All signal wires connecting the Slot Sensor to the control and amplifier must be run separately from all other wiring. This is necessary to comply with the intrinsic safety guidelines.

- 2 Use 2 conductor #18 twisted shielded cable, Belden 8760 or equivalent. For maximum protection, conduit is recommended.
- 3 Maximum cable length from meter to barrier must be less than 1,000 feet.
- 4 Module IS P.F. Control Amplifier KG30-T30/EX or Equimeter Part #950757.
- 5 If meter is isolated, connect wire to earth ground. If meter is not isolated, do not connect green wire to ground.

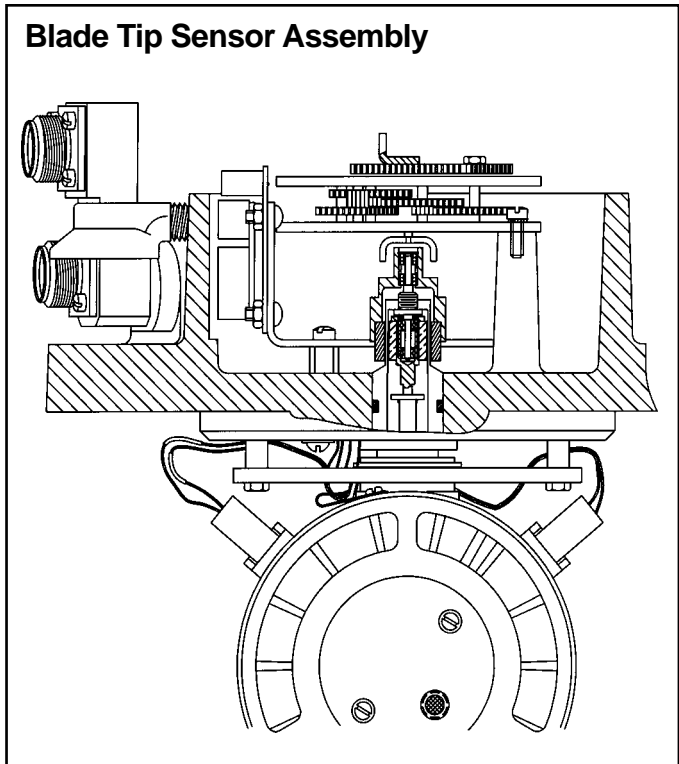

## Blade Tip Sensor (BTS) Description

The BTS, like the Slot Sensor Pulsar, provides an electrical pulse signal that is directly proportional to the Mark-II's and Mark-II-E's mechanical output, but of a much higher frequency than the slot sensor. The pulser signal can be used to actuate a wide variety of remotely located electronic volume totalizers. Tables 11 through 20 detail pulses per unit volume ( $\text{p/ft}^3$  or  $\text{p/m}^3$ ) and pulse output frequency (Hz) for each size (2 through 12-inch) Mark-II and IIE Turbo-Meters.

The rotor blades passing within a short distance of the coil pickup directly generate the signal. The sensor detects the presence or absence of the aluminum rotor blades.

Wiring for the BTS exits the meter through the top plate using either a 1/2"-14 NPT standard conduit fitting or a plug-in connector (similar to the Slot Sensor). To preserve the integrity of the intrinsically safe electrical system, wiring **must** be connected to either the specified safety barrier or the specified intrinsically safe transistor output module. Both of these devices must be located in a safe (i.e. non-hazardous) area in accordance with Diagrams 4 or 5. Note that Diagram 4 is applicable when connecting to an intrinsically safe transformer isolated barrier, and Diagram 5 for use when connecting to intrinsically safe zener diode barrier.

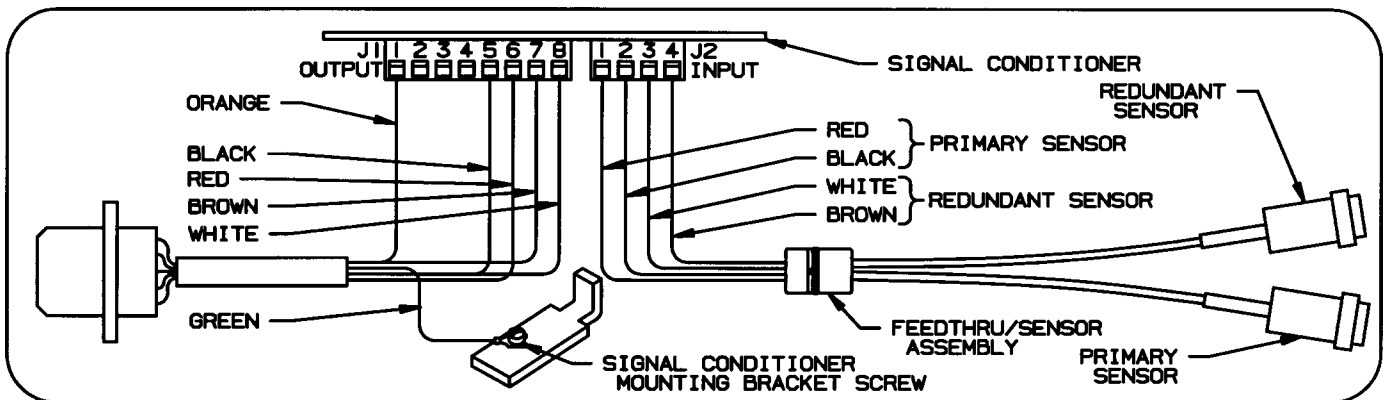

## BTS Factory Retrofit Capability

Unlike the Slot Sensor the BTS is **not** field retrofitable and must be returned to the factory for this service. Because of the Mark-II's design of the top-entry measurement module, only the top plate and module assembly (502) needs to be returned. Current and previous production bodies will accommodate either the Slot Sensor or BTS module. The entire meter must be returned to the factory to add BTS to a Mark-II-E.

The following options for a Slot Sensor to BTS upgrade of the MK-II are possible:

1. Purchase a new complete 502 module with the BTS option.
2. Return a 502 module and have the factory perform these modifications:
  - Remove existing Slot Sensor parts (not required) when replacing the bearings.
  - Modify returned top plate (in some instances this is not possible and a new one would have to be purchased).
  - Modify the returned rotor housing to enable mounting of the BTS coil(s).
  - Install new BTS component parts and re-assemble to the top plate.
  - A Water Test and Calibration prior to shipping will be required.

The BTS option is available with a single coil pulser or dual coils to provide a redundant signal for use by the customer.

## 2" T-4.5 and 3" T-8.8 MK-IIE Turbo-Meter/ With Blade Tip Sensor (BTS) Pulser

T-4.5 Table 11 - Pulses Per Unit of Volume and Pulse Output Frequency Table

Turndown = 201.500000			STANDARD CONSTRUCTION				SPECIAL CONSTRUCTION			
Rotor			13 Blades		13 Blades		13 Blades		13 Blades	
Max. Capacity			4500 ACFH		127 m <sup>3</sup> /H		4500 ACFH		127 m <sup>3</sup> /H	
Mechanical Output			10 ft <sup>3</sup> /Rev.		0.1 m <sup>3</sup> /Rev.		1 ft <sup>3</sup> /Rev.		1 m <sup>3</sup> /Rev.	
Inter. Gear Ratio			122.0555 to 1**		43.10526 to 1**		12.1125 to 1		431.0526 to 1	
CHANGE GEARS			ENGLISH		METRIC		ENGLISH		METRIC	
LG	SM	RATIO	p/ft <sup>3</sup>	Hz	p/m <sup>3</sup>	Hz	p/ft <sup>3</sup>	Hz	p/m <sup>3</sup>	Hz
66-65T	55-54T	1.20370	2960.411	3700.514	104550.212	3688.299	2937.842	3672.303	104550.212	3688.299
66-64T	55-53T	1.20755	2969.864	3712.330	104884.044	3700.076	2947.223	3684.028	104884.044	3700.076
66-69T	55-57T	1.21053	2977.191	3721.488	105142.804	3709.204	2954.494	3693.117	105142.804	3709.204
66-63T	55-52T	1.21154	2979.680	3724.600	105230.716	3712.306	2956.964	3696.205	105230.716	3712.306
66-68T	55-56T	1.21429	2986.437	3733.046	105469.334	3720.724	2963.669	3704.586	105469.334	3720.724
66-67T*	55-55T	1.21818	2996.019	3745.023	105807.739	3732.662	2973.178	3716.473	105807.739	3732.662
66-66T	55-54T	1.22220	3005.956	3757.445	106158.676	3745.042	2983.040	3728.799	106158.676	3745.042
66-65T	55-53T	1.22642	3016.268	3770.335	106522.857	3757.890	2993.273	3741.591	106522.857	3757.890
69-74T	55-52T	1.23077	3026.976	3783.721	106901.045	3771.231	3003.900	3754.875	106901.045	3771.231
66-69T	55-56T	1.23214	3030.355	3787.943	107020.354	3775.440	3007.253	3759.066	107020.354	3775.440
66-68T	55-55T	1.23636	3040.735	3800.919	107386.959	3788.373	3017.554	3711.943	107386.959	3788.373

T-8.8 Table 12 - Pulses Per Unit of Volume and Pulse Output Frequency Table

Turndown = 690.000000			STANDARD CONSTRUCTION				SPECIAL CONSTRUCTION			
Rotor			15 Blades		15 Blades		15 Blades		15 Blades	
Max. Capacity			8800 ACFH		250 m <sup>3</sup> /H		8800 ACFH		250 m <sup>3</sup> /H	
Mechanical Output			100 ft <sup>3</sup> /Rev.		1 m <sup>3</sup> /Rev.		10 ft <sup>3</sup> /Rev.		10 m <sup>3</sup> /Rev.	
Inter. Gear Ratio			122.0555 to 1**		43.10526 to 1**		12.1125 to 1		431.0526 to 1	
CHANGE GEARS			ENGLISH		METRIC		ENGLISH		METRIC	
LG	SM	RATIO	p/ft <sup>3</sup>	Hz	p/m <sup>3</sup>	Hz	p/ft <sup>3</sup>	Hz	p/m <sup>3</sup>	Hz
66-65T	55-56T	1.16071	977.534	2389.527	34522.695	2397.409	970.081	2371.310	34522.695	2397.409
66-64T	55-55T	1.16363	979.995	2395.543	34609.605	2403.445	972.524	2377.280	34609.605	2403.445
66-63T	55-54T	1.16667	982.547	2401.781	34699.734	2409.704	975.056	2383.471	34699.734	2409.704
66-68T	55-58T	1.17241	987.387	2413.612	34870.669	2421.574	979.859	2395.212	34870.669	2421.574
66-67T	55-57T	1.17544	989.934	2419.840	34960.635	2427.822	982.388	2401.392	34960.635	2427.822
66-66T*	55-56T	1.17857	992.573	2426.289	35053.813	2434.293	985.006	2407.792	35053.813	2434.293
66-65T	55-55T	1.18482	995.307	2432.973	35150.380	2440.999	987.719	2414.425	35150.380	2440.999
66-64T	55-54T	1.18519	998.143	2439.905	35250.524	2447.953	990.533	2421.304	35250.524	2447.953
66-63T	55-53T	1.18868	1001.085	2447.098	35345.446	2455.170	993.454	2428.442	35345.446	2455.170
66-69T	55-58T	1.18965	1001.907	2449.107	35383.473	2457.186	994.269	2430.436	35383.473	2457.186
66-68T	55-57T	1.19298	1004.709	2455.957	35482.435	2462.058	997.050	2437.233	35482.435	2464.058

\* Base Change Gear Set

\*\* Brass or Plastic Intermediate Gear Train

NOTE: All current construction MK-II and Mark-IIIE Turbo-Meters have plastic intermediate gear trains.

**EXAMPLE:** (with T-8.8 Base Change Gear Set)

$$p/ft^3 = \frac{(\text{intermediate gear ratio}) \times (\text{number of teeth on large change gear}) \times (\text{turndown})}{(\text{mechanical output}) \times (\text{number of teeth on small change gear})}$$

$$p/ft^3 = \frac{122.0555 \times 66 \times 690.000000}{100 \times 56} = \frac{5,558,407.4700}{5600} = 992.573 \text{ pulses/cubic foot}$$

$$Hz = \frac{p/ft^3 \times \text{maximum capacity}}{3600} = \frac{992.573 \times 8800}{3600} = 2426.289 \text{ pulses per second at the maximum flow rate}$$

**4" T-18 and T-27 MK-II Turbo-Meter/ With Blade Tip Sensor (BTS) Pulsar**

**T-18 Table 13 - Pulses Per Unit of Volume and Pulse Output Frequency Table**

Turndown = 240.000000			STANDARD CONSTRUCTION						SPECIAL CONSTRUCTION			
Rotor			16 Blades		16 Blades		16 Blades		16 Blades		16 Blades	
Max. Capacity			18,000 ACFH		510 m <sup>3</sup> /H		510 m <sup>3</sup> /H		18,000 ACFH		510 m <sup>3</sup> /H	
Mechanical Output			100 ft <sup>3</sup> /Rev.		10 m <sup>3</sup> /Rev.		10 m <sup>3</sup> /Rev.		10 ft <sup>3</sup> /Rev.		1 m <sup>3</sup> /Rev.	
Inter. Gear Ratio			122.0555 to 1**		431.0526(Brass)		430.1073(Plast.)		12.1125 to 1**		43.10526 to 1**	
CHANGE GEARS			ENGLISH		METRIC		METRIC		ENGLISH		METRIC	
LG	SM	RATIO	p/ft <sup>3</sup>	Hz	p/m <sup>3</sup>	Hz	p/m <sup>3</sup>	Hz	p/ft <sup>3</sup>	Hz	p/m <sup>3</sup>	Hz
74-73T	47-48T	1.52083	445.503	2227.513	15733.420	2228.901	15698.916	2224.013	442.106	2210.531	15733.420	2228.901
74-75T	47-49T	1.53061	448.367	2241.836	15834.585	2243.233	15799.860	2238.314	444.949	2224.745	15834.585	2243.233
74-74T	47-48T	1.54167	451.605	2258.027	15948.946	2259.434	15913.970	2254.479	448.163	2240.813	15948.946	2259.434
74-71T	47-46T	1.54348	452.136	2260.680	15967.688	2262.089	15932.670	2257.128	448.689	2243.446	15967.688	2262.089
74-76T	47-49T	1.55102	454.345	2271.727	16045.713	2273.143	16010.525	2268.158	450.882	2254.408	16045.713	2273.143
74-73T*	47-47T	1.55319	454.981	2274.907	16068.174	2276.325	16032.936	2271.333	451.513	2257.564	16068.174	2276.325
74-75T	47-48T	1.56250	457.708	2288.541	16164.473	2289.967	16129.024	2284.945	454.219	2271.094	16164.473	2289.967
74-77T	47-49T	1.57143	460.324	2301.618	16256.841	2303.052	16221.190	2298.002	456.814	2284.071	16256.841	2303.052
74-74T	47-47T	1.57447	461.214	2306.070	16288.285	2307.507	16252.565	2302.447	457.698	2288.489	16288.285	2307.507
74-76T	47-48T	1.58333	463.811	2319.055	16379.999	2320.500	16344.077	2315.411	460.275	2301.375	16379.999	2320.500
74-73T	47-46T	1.58696	464.872	2324.361	16417.482	2325.810	16381.478	2320.709	461.328	2306.641	16417.482	2325.810

**T-27 Table 14 - Pulses Per Unit of Volume and Pulse Output Frequency Table**

Turndown =153.103448			STANDARD CONSTRUCTION						SPECIAL CONSTRUCTION			
Rotor			16 Blades		16 Blades		16 Blades		16 Blades		16 Blades	
Max. Capacity			27,000 ACFH		765 m <sup>3</sup> /H		765 m <sup>3</sup> /H		27,000 ACFH		765 m <sup>3</sup> /H	
Mechanical Output			100 ft <sup>3</sup> /Rev.		10 m <sup>3</sup> /Rev.		10 m <sup>3</sup> /Rev.		10 ft <sup>3</sup> /Rev.		1 m <sup>3</sup> /Rev.	
Inter. Gear Ratio			122.0555 to 1**		431.0526(Brass)		430.1073(Plast.)		12.1125 to 1**		43.10526 to 1**	
CHANGE GEARS			ENGLISH		METRIC		METRIC		ENGLISH		METRIC	
LG	SM	RATIO	p/ft <sup>3</sup>	Hz	p/m <sup>3</sup>	Hz	p/m <sup>3</sup>	Hz	p/ft <sup>3</sup>	Hz	p/m <sup>3</sup>	Hz
71-69T	50-49T	1.40816	263.145	1973.588	9293.263	1974.818	9272.883	1970.488	261.139	1958.543	9293.263	1974.818
71-72T	50-51T	1.41176	263.818	1978.636	9317.031	1979.869	9296.599	1975.527	261.807	1963.552	9317.031	1979.869
71-68T	50-48T	1.41667	264.734	1985.506	9349.382	1986.744	9328.879	1982.387	262.716	1970.370	9349.382	1986.744
71-71T	50-50T	1.42000	265.357	1990.178	9371.381	1991.418	9350.829	1987.051	263.334	1975.006	9371.381	1991.418
71-74T	50-52T	1.42308	265.932	1994.490	9391.687	1995.734	9371.091	1991.357	263.905	1979.285	9391.687	1995.734
71-70T*	50-49T	1.42857	266.959	2002.191	9427.948	2003.439	9407.273	1999.046	264.924	1986.927	9427.948	2003.439
71-73T	50-51T	1.43137	267.482	2006.117	9446.435	2007.367	9425.719	2002.965	265.443	1990.823	9446.435	2007.367
71-69T	50-48T	1.43750	268.627	2014.705	9486.873	2015.961	9466.068	2011.540	266.579	1999.346	9486.873	2015.961
71-72T	50-50T	1.44000	269.094	2018.209	9503.372	2019.467	9482.531	2015.038	267.043	2002.823	9503.372	2019.467
71-71T	50-49T	1.44898	270.773	2030.794	9562.633	2032.060	9541.663	2027.603	268.708	2015.312	9562.633	2032.060
71-74T	50-51T	1.45098	271.146	2033.598	9575.838	2034.866	9554.838	2030.403	269.079	2018.095	9575.838	2034.866

\* Base Change Gear Set

\*\* Brass or Plastic Intermediate Gear Train

NOTE: All current construction MK-II and Turbo-Meters have plastic intermediate gear trains.

**EXAMPLE:** (with T-18 Base Change Gear Set)

$$p/ft^3 = \frac{(\text{intermediate gear ratio}) \times (\text{number of teeth on large change gear}) \times (\text{turndown})}{(\text{mechanical output}) \times (\text{number of teeth on small change gear})}$$

$$p/ft^3 = \frac{122.0555 \times 73 \times 240.000000}{100 \times 47} = \frac{2,138,412.3600}{4700} = 454.981 \text{ pulses/cubic foot}$$

$$Hz = \frac{p/ft^3 \times \text{maximum capacity}}{3600} = \frac{454.9814 \times 18,000}{3600} = 2274.907 \text{ pulses per second at the maximum flow rate}$$

**6" T-35 and T-57 MK-II Turbo-Meter/ With Blade Tip Sensor (BTS) Pulser**

**T-35 Table 15 - Pulses Per Unit of Volume and Pulse Output Frequency Table**

Turndown=98.863636			STANDARD CONSTRUCTION						SPECIAL CONSTRUCTION			
Rotor			20 Blades		20 Blades		20 Blades		20 Blades		20 Blades	
Max. Capacity			35,000 ACFH		990 m <sup>3</sup> /H		990 m <sup>3</sup> /H		35,000 ACFH		990 m <sup>3</sup> /H	
Mechanical Output			100 ft <sup>3</sup> /Rev.		10 m <sup>3</sup> /Rev.		10 m <sup>3</sup> /Rev.		10 ft <sup>3</sup> /Rev.		1 m <sup>3</sup> /Rev.	
Inter. Gear Ratio			122.0555 to 1**		431.0526(Brass)		430.1073(Plast.)		12.1125 to 1**		43.10526 to 1**	
CHANGE GEARS			ENGLISH		METRIC		METRIC		ENGLISH		METRIC	
LG	SM	RATIO	p/ft <sup>3</sup>	Hz	p/m <sup>3</sup>	Hz	p/m <sup>3</sup>	Hz	p/ft <sup>3</sup>	Hz	p/m <sup>3</sup>	Hz
71-72T	50-51T	1.41176	170.356	1656.234	6016.234	1654.481	6003.102	1650.853	169.057	1643.608	6016.296	1654.481
71-68T	50-48T	1.41667	170.947	1661.985	6037.186	1660.226	6023.946	1656.585	169.644	1649.315	6037.186	1660.226
71-71T	50-50T	1.42000	171.349	1665.896	6051.391	1664.132	6038.120	1660.483	170.043	1653.196	6051.391	1664.132
71-74T	50-52T	1.42308	171.721	1669.505	6064.503	1667.738	6051.204	1664.081	170.411	1656.778	6064.503	1667.738
71-70T	50-49T	1.42857	172.384	1675.951	6087.918	1674.178	6074.567	1670.506	171.069	1663.175	6087.918	1674.178
71-73T*	50-51T	1.43137	172.722	1679.238	6099.855	1677.460	6086.478	1673.782	171.405	1666.436	6099.855	1677.460
71-69T	50-48T	1.43750	173.461	1686.426	6125.968	1684.641	6112.533	1680.947	172.139	1673.570	6125.968	1684.641
71-72T	50-50T	1.44000	173.763	1689.359	6136.622	1687.571	6123.164	1683.870	172.438	1676.480	6136.622	1687.571
71-71T	50-49T	1.44898	174.846	1699.894	6174.888	1698.094	6161.347	1694.370	173.513	1686.934	6174.888	1698.094
71-74T	50-51T	1.45098	175.088	1702.241	6183.415	1700.439	6169.855	1696.710	173.753	1689.264	6183.415	1700.439
71-70T	50-48T	1.45833	175.975	1710.867	6214.750	1709.056	6201.121	1705.308	174.633	1697.824	6214.750	1709.056

**T-57 Table 16 - Pulses Per Unit of Volume and Pulse Output Frequency Table**

Turndown=60.576923			STANDARD CONSTRUCTION						SPECIAL CONSTRUCTION			
Rotor			20 Blades		20 Blades		20 Blades		20 Blades		20 Blades	
Max. Capacity			57,000 ACFH		1615 m <sup>3</sup> /H		1615 m <sup>3</sup> /H		57,000 ACFH		1615 m <sup>3</sup> /H	
Mechanical Output			100 ft <sup>3</sup> /Rev.		10 m <sup>3</sup> /Rev.		10 m <sup>3</sup> /Rev.		10 ft <sup>3</sup> /Rev.		1 m <sup>3</sup> /Rev.	
Inter. Gear Ratio			122.0555 to 1**		431.0526(Brass)		430.1073(Plast.)		12.1125 to 1**		43.10526 to 1**	
CHANGE GEARS			ENGLISH		METRIC		METRIC		ENGLISH		METRIC	
LG	SM	RATIO	p/ft <sup>3</sup>	Hz	p/m <sup>3</sup>	Hz	p/m <sup>3</sup>	Hz	p/ft <sup>3</sup>	Hz	p/m <sup>3</sup>	Hz
71-71T	50-51T	1.39215	102.933	1629.765	3635.178	1630.781	3627.206	1627.205	102.148	1617.341	3635.178	1630.781
71-70T	50-50T	1.40000	103.512	1638.947	3655.658	1639.969	3647.641	1636.372	102.723	1626.453	3655.658	1639.969
71-73T	50-52T	1.40385	103.797	1643.450	3665.701	1644.474	3657.662	1640.868	103.006	1630.921	3665.701	1644.474
71-69T	50-49T	1.40816	104.116	1648.504	3676.973	1649.531	3668.910	1645.914	103.322	1635.936	3676.973	1649.531
71-72T	50-51T	1.41176	104.382	1652.720	3686.377	1653.750	3678.293	1650.123	103.587	1640.120	3686.377	1653.750
71-68T*	50-48T	1.41667	104.745	1658.458	3699.177	1659.492	3691.065	1655.853	103.946	1645.815	3699.177	1659.492
71-71T	50-50T	1.42000	104.991	1662.361	3707.881	1663.397	3699.750	1659.749	104.191	1649.688	3707.881	1663.397
71-74T	50-52T	1.42308	105.219	1665.963	3715.916	1667.001	3707.767	1663.345	104.417	1653.262	3715.916	1667.001
71-70T	50-49T	1.42857	105.625	1672.395	3730.263	1673.437	3722.082	1669.768	104.820	1659.645	3730.263	1673.437
71-73T	50-51T	1.43137	105.832	1675.674	3737.577	1676.719	3729.381	1673.042	105.025	1662.900	3737.577	1676.719
71-69T	50-48T	1.43750	106.285	1682.848	3753.577	1683.896	3745.345	1680.204	105.475	1670.018	3753.577	1683.896

\* Base Change Gear Set

\*\* Brass or Plastic Intermediate Gear Train

NOTE: All current construction MK-II Turbo-Meters have plastic intermediate gear trains.

**EXAMPLE:** (with T-35 Base Change Gear Set)

$$p/ft^3 = \frac{(\text{intermediate gear ratio}) \times (\text{number of teeth on large change gear}) \times (\text{turndown})}{(\text{mechanical output}) \times (\text{number of teeth on small change gear})}$$

$$p/ft^3 = \frac{122.0555 \times 73 \times 98.863636}{100 \times 51} = \frac{880,880.0882}{5100} = 172.722 \text{ pulses/cubic foot}$$

$$Hz = \frac{p/ft^3 \times \text{maximum capacity}}{3600} = \frac{172.7216 \times 35,000}{3600} = 1679.238 \text{ pulses per second at the maximum flow rate}$$

**8" T-60 and T-90 MK-II Turbo-Meter/ With Blade Tip Sensor (BTS) Pulser**

**T-60 Table 17 - Pulses Per Unit of Volume and Pulse Output Frequency Table**

Turndown = 388.235294			STANDARD CONSTRUCTION				SPECIAL CONSTRUCTION					
Rotor			20 Blades		20 Blades		20 Blades		20 Blades		20 Blades	
Max. Capacity			60,000 ACFH		1699 m <sup>3</sup> /H		60,000 ACFH		1699 m <sup>3</sup> /H		1699 m <sup>3</sup> /H	
Mechanical Output			1000 ft <sup>3</sup> /Rev.		10 m <sup>3</sup> /Rev.		100 ft <sup>3</sup> /Rev.		100 m <sup>3</sup> /Rev.		100 m <sup>3</sup> /Rev.	
Inter. Gear Ratio			122.0555 to 1**		43.10526 to 1**		12.1125 to 1**		431.0526 (Brass)		430.1073 (Plastic)	
CHANGE GEARS			ENGLISH		METRIC		ENGLISH		METRIC		METRIC	
LG	SM	RATIO	p/ft <sup>3</sup>	Hz	p/m <sup>3</sup>	Hz	p/ft <sup>3</sup>	Hz	p/m <sup>3</sup>	Hz	p/m <sup>3</sup>	Hz
74-77T	47-49T	1.57143	74.464	1241.069	2629.783	1241.112	73.896	1231.607	2629.783	1241.112	2624.016	1238.390
74-74T	47-47T	1.57447	74.608	1243.469	2634.870	1243.512	74.039	1233.989	2634.870	1243.512	2629.091	1240.785
74-76T	47-48T	1.58333	75.028	1250.471	2649.706	1250.514	74.456	1240.937	2649.706	1250.514	2643.895	1247.771
74-73T	47-46T	1.58696	75.200	1253.332	2655.769	1253.375	74.627	1243.777	2655.769	1253.375	2649.945	1250.627
74-75T	47-47T	1.59574	75.616	1260.273	2670.476	1260.316	75.040	1250.665	2670.476	1260.316	2664.620	1257.552
74-77T*	47-48T	1.60417	76.015	1266.924	2684.570	1266.968	75.436	1257.266	2684.570	1266.968	2678.683	1264.190
74-74T	47-46T	1.60870	76.230	1270.501	2692.149	1270.545	75.649	1260.815	2692.149	1270.545	2686.246	1267.759
74-76T	47-47T	1.61702	76.625	1277.076	2706.082	1277.121	76.040	1267.340	2706.082	1277.121	2700.148	1274.320
74-73T	47-45T	1.62222	76.871	1281.184	2714.786	1281.228	76.285	1271.417	2714.786	1281.228	2708.833	1278.419
74-75T	47-46T	1.63043	77.260	1287.670	2728.530	1287.715	76.671	1277.853	2728.530	1287.715	2722.546	1284.891
74-77T	47-47T	1.63830	77.633	1293.880	2741.689	1293.925	77.041	1284.016	2741.689	1293.925	2735.676	1291.087

**T-90 Table 18 - Pulses Per Unit of Volume and Pulse Output Frequency Table**

Turndown = 247.826086			STANDARD CONSTRUCTION				SPECIAL CONSTRUCTION					
Rotor			20 Blades		20 Blades		20 Blades		20 Blades		20 Blades	
Max. Capacity			90,000 ACFH		2549 m <sup>3</sup> /H		90,000 ACFH		2549 m <sup>3</sup> /H		2549 m <sup>3</sup> /H	
Mechanical Output			1000 ft <sup>3</sup> /Rev.		10 m <sup>3</sup> /Rev.		100 ft <sup>3</sup> /Rev.		100 m <sup>3</sup> /Rev.		100 m <sup>3</sup> /Rev.	
Inter. Gear Ratio			122.0555 to 1**		43.10526 to 1**		12.1125 to 1**		431.0526 (Brass)		430.1073 (Plastic)	
CHANGE GEARS			ENGLISH		METRIC		ENGLISH		METRIC		METRIC	
LG	SM	RATIO	p/ft <sup>3</sup>	Hz	p/m <sup>3</sup>	Hz	p/ft <sup>3</sup>	Hz	p/m <sup>3</sup>	Hz	p/m <sup>3</sup>	Hz
71-70T	50-51T	1.37254	41.518	1037.940	1466.240	1038.180	41.201	1030.027	1466.240	1038.180	1463.025	1035.903
71-69T	50-50T	1.38000	41.743	1043.575	1474.200	1043.815	41.425	1035.619	1474.200	1043.815	1470.967	1041.526
71-72T	50-52T	1.38461	41.883	1047.065	1479.130	1047.306	41.563	1039.082	1479.130	1047.306	1475.887	1045.010
71-68T	50-49T	1.38775	41.978	1049.439	1482.484	1049.681	41.658	1041.439	1482.484	1049.681	1479.233	1047.379
71-71T	50-51T	1.39215	42.111	1052.768	1487.187	1053.011	41.790	1044.742	1487.187	1053.011	1483.925	1050.701
71-70T*	50-50T	1.40000	42.348	1058.699	1495.565	1058.943	42.025	1050.628	1495.565	1058.943	1492.285	1056.621
71-73T	50-52T	1.40385	42.464	1061.607	1499.674	1061.852	42.141	1053.514	1499.674	1061.852	1496.385	1059.524
71-69T	50-49T	1.40816	42.595	1064.872	1504.286	1065.118	42.270	1056.754	1504.286	1065.118	1500.987	1062.782
71-72T	50-51T	1.41176	42.704	1067.595	1508.133	1067.842	42.378	1059.457	1508.133	1067.842	1504.826	1065.500
71-68T	50-48T	1.41667	42.852	1071.302	1513.369	1071.550	42.525	1063.135	1513.369	1071.550	1510.051	1069.200
71-71T	50-50T	1.42000	42.953	1073.823	1516.930	1074.071	42.625	1065.637	1516.930	1074.071	1513.604	1071.715

\* Base Change Gear Set

\*\* Brass or Plastic Intermediate Gear Train

NOTE: All current construction MK-II Turbo-Meters have plastic intermediate gear trains.

**EXAMPLE:** (with T-60 Base Change Gear Set)

$$p/ft^3 = \frac{(\text{intermediate gear ratio}) \times (\text{number of teeth on large change gear}) \times (\text{turndown})}{(\text{mechanical output}) \times (\text{number of teeth on small change gear})}$$

$$p/ft^3 = \frac{122.0555 \times 77 \times 388.235294}{1000 \times 48} = \frac{3,648,741.4754}{48,000} = 76.015 \text{ pulses/cubic foot}$$

$$Hz = \frac{p/ft^3 \times \text{maximum capacity}}{3600} = \frac{76.0154 \times 60,000}{3600} = 1266.924 \text{ pulses per second at the maximum flow rate}$$

**12" T-140 and T-230 MK-II Turbo-Meter/ With Blade Tip Sensor (BTS) Pulser**

**T-140 Table 19 - Pulses Per Unit of Volume and Pulse Output Frequency Table**

Turndown = 180.000000			STANDARD CONSTRUCTION				SPECIAL CONSTRUCTION					
Rotor			24 Blades		24 Blades		24 Blades		24 Blades		24 Blades	
Max. Capacity			140,000 ACFH		3964 m <sup>3</sup> /H		140,000 ACFH		3964 m <sup>3</sup> /H		3964 m <sup>3</sup> /H	
Mechanical Output			1000 ft <sup>3</sup> /Rev.		10 m <sup>3</sup> /Rev.		100 ft <sup>3</sup> /Rev.		100 m <sup>3</sup> /Rev.		100 m <sup>3</sup> /Rev.	
Inter. Gear Ratio			122.0555 to 1**		43.10526 to 1**		12.1125 to 1**		431.0526 (Brass)		430.1073 (Plastic)	
CHANGE GEARS			ENGLISH		METRIC		ENGLISH		METRIC		METRIC	
LG	SM	RATIO	p/ft <sup>3</sup>	Hz	p/m <sup>3</sup>	Hz	p/ft <sup>3</sup>	Hz	p/m <sup>3</sup>	Hz	p/m <sup>3</sup>	Hz
66-68T	55-53T	1.28302	28.188	1096.197	995.458	1096.142	27.973	1087.840	995.488	1096.142	993.304	1093.739
66-67T	55-52T	1.28846	28.307	1100.847	999.710	1100.792	28.092	1092.454	999.710	1100.792	997.518	1098.378
69-70T	52-54T	1.29630	28.480	1107.541	1005.789	1107.486	28.263	1099.097	1005.789	1107.486	1003.584	1105.057
66-69T	55-53T	1.30189	28.602	1112.317	1010.127	1112.262	28.384	1103.837	1010.127	1112.262	1007.912	1109.823
66-68T	55-52T	1.30769	28.730	1117.277	1014.632	1117.222	28.511	1108.760	1014.632	1117.222	1012.406	1114.772
69-67T*	52-51T	1.31373	28.863	1122.432	1019.313	1122.376	28.643	1113.875	1019.313	1122.376	1017.077	1119.915
69-70T	52-53T	1.32075	29.017	1128.438	1024.767	1128.382	28.796	1119.835	1024.767	1128.382	1022.519	1125.907
66-69T	55-52T	1.32692	29.152	1133.708	1029.553	1133.652	28.930	1125.065	1029.553	1133.652	1027.295	1131.166
71-68T	50-51T	1.33333	29.293	1139.185	1034.526	1139.128	29.070	1130.500	1034.526	1139.128	1032.258	1136.630
69-67T	52-50T	1.34000	29.440	1144.881	1039.699	1144.824	29.215	1136.153	1039.699	1144.824	1037.419	1142.313
71-70T	50-51T	1.37255	30.155	1172.690	1064.953	1172.632	29.925	1163.750	1064.953	1172.632	1062.618	1170.061

**T-230 Table 20 - Pulses Per Unit of Volume and Pulse Output Frequency Table**

Turndown = 180.000000			STANDARD CONSTRUCTION				SPECIAL CONSTRUCTION					
Rotor			24 Blades		24 Blades		24 Blades		24 Blades		24 Blades	
Max. Capacity			230,000 ACFH		6513 m <sup>3</sup> /H		230,000 ACFH		6513 m <sup>3</sup> /H		6513 m <sup>3</sup> /H	
Mechanical Output			1000 ft <sup>3</sup> /Rev.		10 m <sup>3</sup> /Rev.		100 ft <sup>3</sup> /Rev.		100 m <sup>3</sup> /Rev.		100 m <sup>3</sup> /Rev.	
Inter. Gear Ratio			122.0555 to 1**		43.10526 to 1**		12.1125 to 1**		431.0526 (Brass)		430.1073 (Plastic)	
CHANGE GEARS			ENGLISH		METRIC		ENGLISH		METRIC		METRIC	
SM	LG	RATIO	p/ft <sup>3</sup>	Hz	p/m <sup>3</sup>	Hz	p/ft <sup>3</sup>	Hz	p/m <sup>3</sup>	Hz	p/m <sup>3</sup>	Hz
50-49T	71-69T	0.71014	15.602	996.787	550.998	996.847	15.483	989.188	550.998	996.847	549.789	994.661
50-51T	71-72T	0.70833	15.562	994.244	549.592	994.304	15.443	986.664	549.592	994.304	548.387	992.123
50-48T	71-68T	0.70588	15.508	990.803	547.690	990.863	15.390	983.250	547.690	990.863	546.489	988.690
50-50T	71-71T	0.70423	15.472	988.478	546.405	988.537	15.354	980.942	546.405	988.537	545.206	986.369
50-52T	71-74T	0.70270	15.438	986.340	545.223	986.400	15.321	978.821	545.223	986.400	544.028	984.237
50-49T*	71-70T	0.70000	15.379	982.547	543.126	982.606	15.262	975.056	543.126	982.606	541.935	980.451
50-51T	71-73T	0.69863	15.349	980.624	542.063	980.683	15.232	973.148	542.063	980.683	540.875	978.532
50-48T	71-69T	0.69565	15.283	976.444	539.753	976.503	15.167	969.000	539.753	976.503	538.569	974.361
50-50T	71-72T	0.69444	15.257	974.749	538.816	974.807	15.141	967.318	538.816	974.807	537.634	972.670
50-49T	71-71T	0.69014	15.162	968.708	535.477	968.766	15.047	961.323	535.477	968.766	534.302	966.642
50-51T	71-74T	0.68919	15.141	967.372	534.738	967.431	15.026	959.997	534.738	967.431	533.566	965.309

\* Base Change Gear Set

\*\* Brass or Plastic Intermediate Gear Train

NOTE: All current construction MK-II Turbo-Meters have plastic intermediate gear trains.

**EXAMPLE:** (with T-140 Base Change Gear Set)

$$p/ft^3 = \frac{(\text{intermediate gear ratio}) \times (\text{number of teeth on large change gear}) \times (\text{turndown})}{(\text{mechanical output}) \times (\text{number of teeth on small change gear})}$$

$$p/ft^3 = \frac{122.0555 \times 67 \times 180.000000}{1000 \times 51} = \frac{1,471,989.3300}{51,000} = 28.863 \text{ pulses/cubic foot}$$

$$Hz = \frac{p/ft^3 \times \text{maximum capacity}}{3600} = \frac{28.8625 \times 140,000}{3600} = 1122.432 \text{ pulses per second at the maximum flow rate}$$

**Diagram 4**  
**Connection Diagram for Equimeter Mark-II Turbo-Meter**  
**With Blade Tip Sensor to Intrinsically Safe Transformer Isolated Barrier**

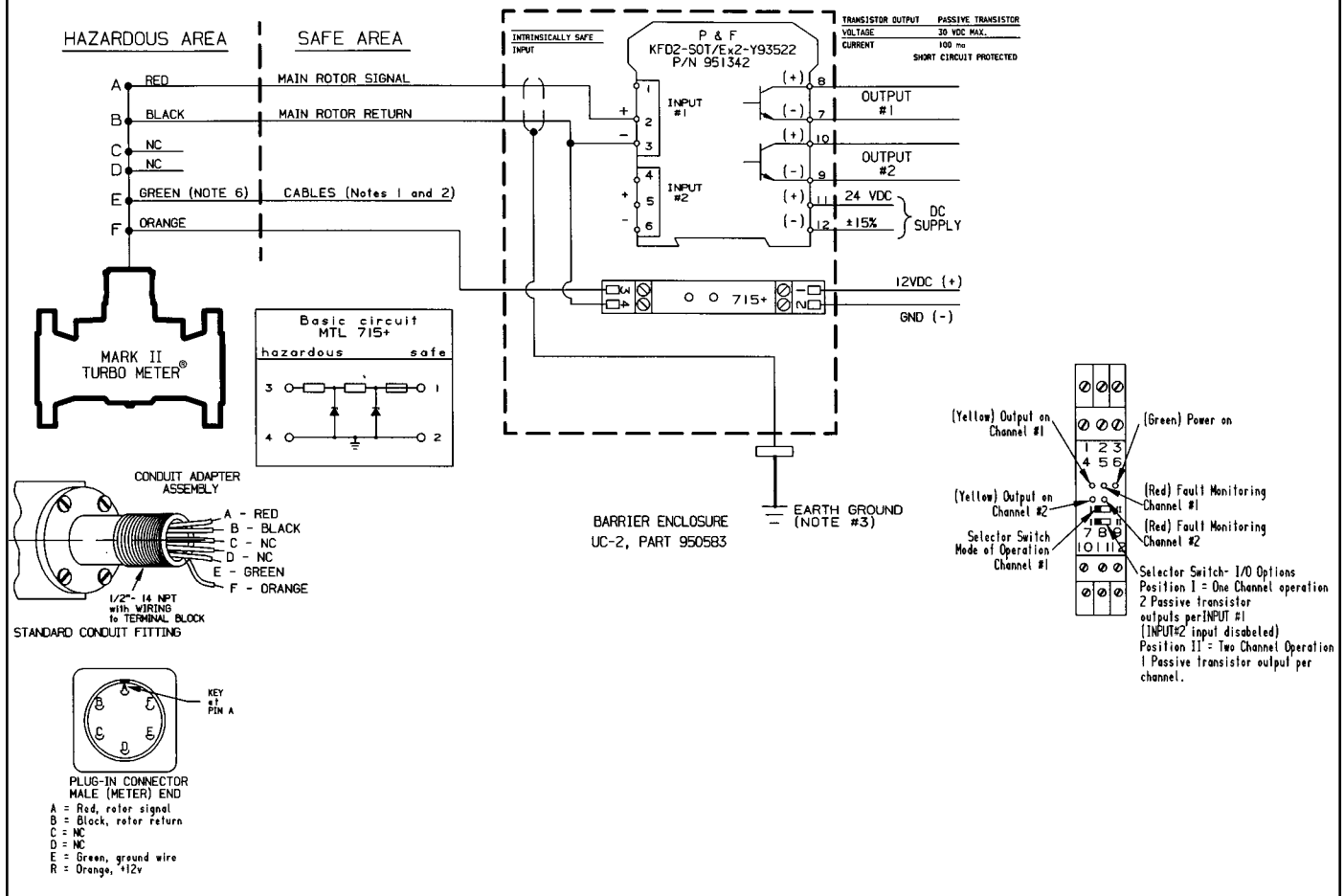

See Back Cover for Diagram 5.

**Diagram 5**  
**Connection Diagram for Equimeter Mark-II Turbo-Meter**  
**With Blade Tip Sensor to Intrinsically Safe Zener Diode Barrier**

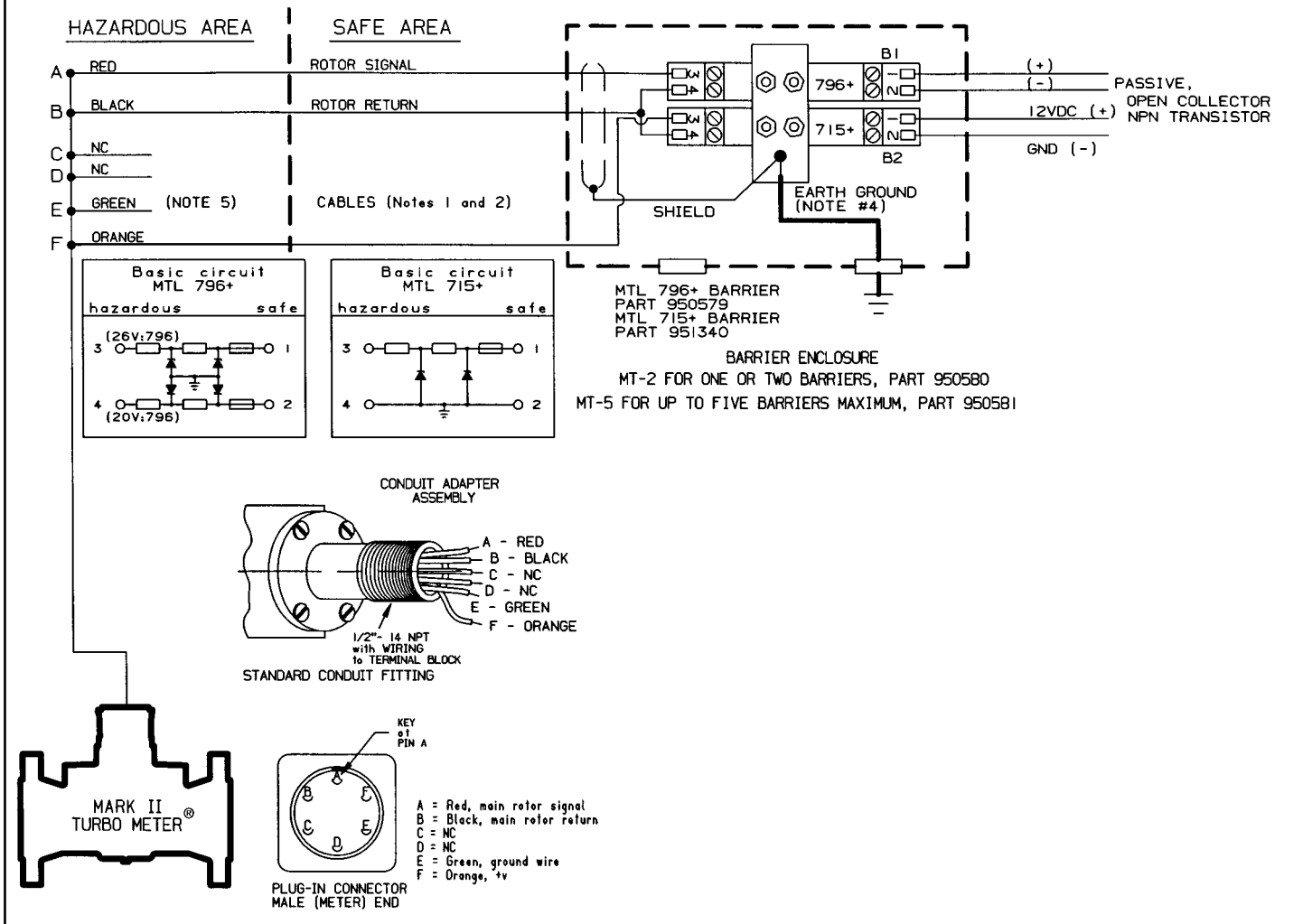

**Equimeter Incorporated, 805 Liberty Boulevard, DuBois, PA 15801**  
**(814) 371-8000**  
**FAX (814) 375-8460**  
**www.equimeter.com**



Equimeter Incorporated  
 805 Liberty Boulevard  
 P.O. Box 528  
 DuBois, PA 15801

An Invensys Company



**LIMITED WARRANTY** Seller warrants the Goods to be free from defects in materials manufactured by Seller and in Seller's workmanship for a period of [one (1) year] after tender of delivery (the "Warranty Period"). **THIS LIMITED WARRANTY (a) IS IN LIEU OF, AND SELLER DISCLAIMS AND EXCLUDES, ALL OTHER WARRANTIES, STATUTORY, EXPRESS OR IMPLIED, INCLUDING, WITHOUT LIMITATION, ANY WARRANTY OF MERCHANTABILITY OR FITNESS FOR A PARTICULAR PURPOSE, OR OF CONFORMITY TO MODELS OR SAMPLES; (b)** does not apply to any Goods which have been (i) repaired, altered or improperly installed; (ii) subjected to improper use or storage; (iii) used or incorporated with other materials or equipment, after Buyer or anyone using the Goods has, or reasonably should have, knowledge of any defect or nonconformance of the Goods; or (iv) manufactured, fabricated or assembled by anyone other than Seller; **(c)** shall not be effective unless Buyer notifies Seller in writing of any purported defect or nonconformance within [thirty (30) days] after Buyer discovers or should have reasonably discovered such purported defect or nonconformance; and **(d)** shall only extend to Buyer and not to any subsequent buyers or users of the Goods. Buyer shall provide Seller access to the Goods as to which Buyer claims a purported defect or nonconformance; upon request by Seller, Buyer shall, at its own risk and expense, promptly return the Goods in question to Seller's Plant.