

Introduction

The electromagnetic flowmeter uses Faraday’s Law of electromagnetic induction to measure the process flow. The device consists of two units: a detector, through which the fluid to be measured flows and in which low-level signals proportional to flow rates are obtained; and a converter, which supplies excitation current to the detector, and amplifies the signals from the detector and then processes and converts the signals into the 4–20mA dc current signal or communication signal. With the unique patented **Mount- Anywhere** magnetic field distribution technology, the meter is highly immune to upstream flow disturbances. Combined with a multi-functional converter LF610 (combined type) or LF612 (separate type) equipped with its patented **Noise-Sentry** original noise-suppression circuit and advanced algorithms. The LF430 has a very high tolerance to noise, giving the unit a very stable output even for slurry fluid measurement. IR (Infrared) switches enable parameter setting of the converter without removing the cover. Flow direction can be set in either way, and its unique 128 x 128 dot matrix LCD display allows the LCD to be rotated electronically to 90, 180 and 270 degrees without opening the cover.

The AF900 hand-held terminal (HART*¹ communicator) can be used to communicate with the flowmeter from a remote place. PROFIBUS-PA*² interface is available as an option.

- *1: HART protocol (Highway Addressable Remote Transducer) is a communication protocol for industrial sensors recommended by the HCF (HART Communication Foundation).
- *2: PROFIBUS is the communications protocol for factory and process automation that the PROFIBUS Organization recommends. Instead of analog control with a conventional analog signal (4-20mA), it is fieldbus which digitizes all signals. Flowmeters support PROFIBUS-PA.

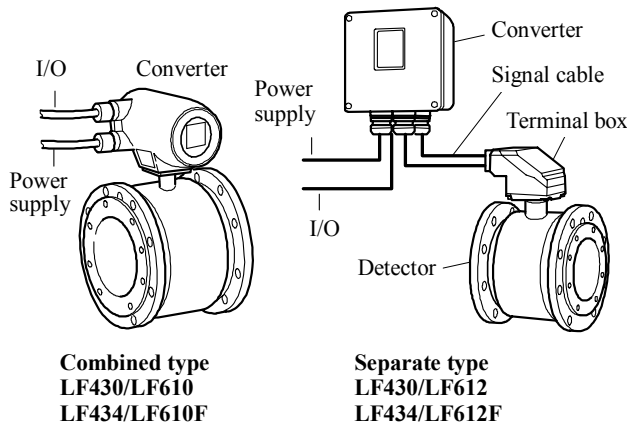

Figure1. Configuration



LF430/LF610
LF434/LF610F **LF430**
LF434 **LF612**
LF612F

Figure2. LF430 Mount-Anywhere series Flowmeters



Certification number
Z01207

Specifications

Overall Specifications

Measurement range in terms of flow velocity:
0–1.0 ft/s to 0–32.8 ft/s (0–0.3 m/s to 0–10 m/s).
0–0.3 ft/s to 0–1.0 ft/s (0–0.1 m/s to 0–0.3 m/s)
range is available optionally.

Accuracy: ±0.2 % of Rate*

- * This pulse output error result is established under standard operating conditions at Toshiba's flow calibration facility, Fuchu Japan. (NIST Traceable).
- * Individual meter measurement error may vary up to ±0.5% of Rate at 1.64 ft/s (0.5m/s) or more and ±0.3% of rate ±0.039 inch/s (1mm/s) at 1.64 ft/s or less.
- * Current output: plus ± 8µA (0.05% of span).
- * Refer to individual calibration data for each individual meter's measurement error.

Fluid conductivity: 5µS/cm minimum

Fluid temperature:
14 to 248 °F (-10 to +120 °C):
Teflon PFA lined flowmeter
14 to 176 °F (-10 to +80 °C):
EPDM rubber lined flowmeter

Ambient temperature: -4 to 140 °F (-20 to +60 °C)

Structure:

Standard — IP 67 and NEMA 4X Watertight

Option — IP68 and NEMA 6P Submersible type is available only when EPDM rubber liner is used, the coating for this type is black tar epoxy resin coating 0.5mm. This type of flowmeter is submersible to 5 m in water.

Power consumption:

17W (27VA) or less

19W (29VA) or less (with PROFIBUS)

Conformance to European Community Directives:

EMC directive 89/336/EEC

The low voltage 93/68/EEC

PED 97/23/EC (Note)

Note : See table 1 for detail.

Approved hazardous location certifications:

Model: LF434/LF610F and LF434/LF612F

cFMus explosion proof:

FM Class I, Division 2, Groups A,B,C, and D.

FM Class II, Division 2, Groups E, F and G.

FM Class III.

Detector and converter combination:

LF430/LF610: Combined type for standard specification.

LF430/LF612: Separate type for standard specification.

LF434/LF610F: Combined type with Ex approval of Class I, Division 2 (cFMus).

LF434/LF612F: Separate type with Ex approval of Class I, Division 2 (cFMus).

Mount-Anywhere Technology:

With TOSHIBA's unique patented magnetic field distribution technology, the meter is highly immune to upstream flow disturbances.

A minimum of 1D (one diameter) length of upstream straight pipe from the flange is required to maintain the performance specification.

Note : The test results were obtained and demonstrated at TOSHIBA's flow calibration facility, Fuchu Japan..

■ **Model LF430 and LF434 Detectors**

Mounting style: Flange connection type

Fluid pressure:

-15 psi or -1.0 bar (-0.1 MPa) to the pressure limited by the connection flange.

Note: The test pressure before shipping from the factory is equal to twice the nominal pressure rating of the customer specified flange connection during 15 minutes.

Connection flange standards:

ANSI 150, ANSI 300, BS10, BS16, DIN PN10, DIN PN16, JIS10K, JIS16K, JIS20K

Principal materials:

Case — carbon steel

Flange material —

1/2" to 8" (15mm to 200mm): 304 stainless steel

10" to 18" (250mm to 450mm): carbon steel

Linings —

1/2" to 2" (15 to 50mm): Teflon PFA

3" to 16" (80 to 400mm):

EPDM rubber (std.) & Teflon PFA (opt.)

18" (450mm) : EPDM rubber

Note: Teflon liners are mechanically retained for full vacuum service.

Electrodes —

Type-Super smooth, polished with self cleaning finish, and non stick shape

316L stainless steel (std.)

Hastelloy C equivalent (std.) (in case of Teflon PFA lining)

Note: Electrodes are electro-chemically polished after mechanically buffed.

Grounding rings — 316 stainless steel (std.)

Note: See Table 6 for optional materials and other related information.

Measuring tube material — 304 stainless steel

Coating: Corrosion resistant phthalic acid resin coating (std.), pearl-gray colored

Note: If the optional IP68 and NEMA 6P structure is specified, the coating is black tar epoxy resin coating 0.5 mm.

Dimensions and weights: See Figure 3 and 4.

Cable connection port: for separate type detectors.

Cable gland —

LF430: Provided as standard, R(PT) 1/2 male screws.

LF434: Not provided, 3/4-14NPT male screws are required.

Applicable diameter —

0.433 to 0.512 inch (11 to 13mm)

■ **Model LF610 and LF612 converters**

Input signals

Analog signal — the voltage signal from detector, proportional to process flow rate (for LF612 separate type converter).

Digital input DI (opt.)

Signal type: 20 to 30Vdc voltage signal

Input resistance: 2.7k Ω

Number of inputs: one point

DI function — One of the following functions can be assigned to the optional DI signal.

Range switching — Selects either the higher or lower range in the unidirectional or bidirectional 2-range setting.

Totalizer control — Starts and stops the built-in totalizer.

Fixed-value outputs — Outputs fixed-values for current and pulse outputs.

Zero adjustment — Executes zero adjustment (on-stream at zero flow rate).

Output signals

Current output:

4–20mA_{dc} (load resistance 0 to 750 Ω)

Note: The current output cannot be used with the PROFIBUS-PA communication.

Digital outputs — One point (std.) and one more point is optionally available as follows.

Digital output DO1 (std.):

Output type: Transistor open collector

Number of outputs: One point

Output capacity: 30V_{dc}, 200mA maximum

Digital output DO2 (opt.):

Output type:

Solid-state relay output (non polarity)

Number of outputs: One point

Output capacity: 150V_{dc}, 150mA maximum or 150V_{ac} (peak to peak), 100mA maximum

DO1 and DO2 functions — One of the following functions can be assigned to DO1 (std.) and/or DO2 (opt.)

- **Pulse output (available only for DO1, DO2)**

Pulse rate: 3.6 to 36,000,000 pulses/hr (DO1)

3.6 to 360,000 pulses/hr (DO2)

(Over 3,600,000 pulses/hr, auto-setting)

Pulse width: 0.5 to 500ms (but less than half of the period for 100% flow rate)

Note: The same and simultaneous pulse is not available between DO1 and DO2.)

- **Multi-range selection outputs (Note 1)**

- **High, High high, Low, and/or Low low alarm outputs (Note 2)**

- **Empty pipe alarm output (Note 2)**

- **Preset count output**

- **Converter failure alarm output**

Note 1: Two outputs (DO1 and DO2) are needed for 4-range switching and forward/reverse 2-range switching.

Note 2: Normal Open (default set) or Normal Close is selected for alarm outputs when programming. When power failure occurs, unit will be fault to Normal Open.

Communications output :

- **HART (std.)** — Digital signal is superimposed on 4–20mA_{dc} current signal as follows:

Conforms to HART protocol

Load resistance: 240 to 750 Ω

Load capacitance: 0.25 μ F maximum

Load inductance: 4mH maximum

- **PROFIBUS(opt.)**

Protocol: PROFIBUS-PA

Baud rate: 31.25kbps

Bus voltage: 9-30V_{DC}

Consumption electric current of bus: less than 16mA

Manufacture Ident-No.: 093B_{HEX}

Standard Ident-No.: 9740_{HEX}

Slave address: 0-126 (Default address is 126)

Profile: Profile Ver.3.01 for Process Control Devices

Function blocks: AI(Flow) \times 1 , Totalizer \times 1

LCD display:

Full dot-matrix 128 \times 128 dot LCD display (back-light provided)

The data on the LCD inside the converter can rotate to 90, 180, and 270 degrees by a software, without rotating the indicator itself. (Combined type only)

Parameter settings — Parameters can be set as follows:

- **IR Switches:** Three key switches are provided to set configuration parameters.

- **Digital communication:** The AF900 hand-held terminal or PROFIBUS is needed to set parameters.

- **Zero adjustment:** Zero point adjustment can be started by pressing the switch in the converter.

- **Damping:** 0.5 to 60 seconds (selectable in one second increments)

“Field re-verification” Mag-Prover– Toshiba’s Zero span calibration tool allows unit to be re-calibrated and verified using an internal software program (For more information contact Toshiba International Corp.)

Conditions when power fails:

Parameter setting values are stored in non-volatile memory and the values will be restored when the power returns to normal condition. The outputs and display will remain as follows when power fails.

- Current output: 0mA_{dc}

- Digital output: OFF
- LCD display: No display
- PROFIBUS: No communication

Power supply:

One of the following can be selected:

- 100 to 240Vac, 50/60Hz (std.)
(allowable voltage 80 to 264Vac)
- 24Vdc (allowable voltage 18 to 36Vdc)
- 110Vdc (allowable voltage 90 to 130Vdc)

Surge protection:

Arresters are installed in the power supply and a current signal output circuit to help protect the meter from lightning and improve personnel safety.

Case: Aluminum alloy (equal to IP 67)

Coating: Acrylic resin-baked coating, pearl-gray colored

Cable connection port:

Cable glands —

- LF610 and LF612 without cFMus Approval:
Provided as standard, OD of cable 11~13mm
Material Nylon 66
G (PF) 1/2 male screws.
- LF610F and LF612F with cFMus Approval:
Not provided, 1/2~14NPT male screws are required.

Applicable diameter —

0.433 to 0.512 inch (11 to 13mm)

Note: When PROFIBUS option is specified, cable gland size is $\phi 6\sim 8\text{mm}$ for signal cable, $\phi 11\sim 13\text{mm}$ for power cable

Vibration resistance:

No resonance to the following levels of vibration:

- 10 to 150Hz with acceleration of 9.8m/s^2
- Vibration of 30Hz with 29.4 m/s^2 in 4h in each direction will not cause any defect to unit.

Note: Avoid using the flowmeter in an environment with constant vibration.

Dimensions and Weights:

See Figure 5 (for Separate type)

MTBF:

Converter: 220,000 hours (25 years) at 77 °F (25 °C)
based on strict military specification
MIL-HDBK-217F

Detector: 350,000 hours (40 years) at 77 °F (25 °C)
based on strict military specification
MIL-HDBK-217F

■ PED matrix in each flange connection.

The following sizes fall under the category for PED in each flange connection when the meter ships to EU. All of them had complied with it from a notified body.

Table1. PED matrix in each flange connection

Flange standard	Meter size
DIN PN 16 and BS 16	150 to 400mm (6 to 16 inch)
DIN PN 10 and BS 10	250 to 400mm (10 to 16 inch)
ANSI 150 and JIS10K	6 to 16 inch (150 to 400mm)

Installation

■ Dimensions

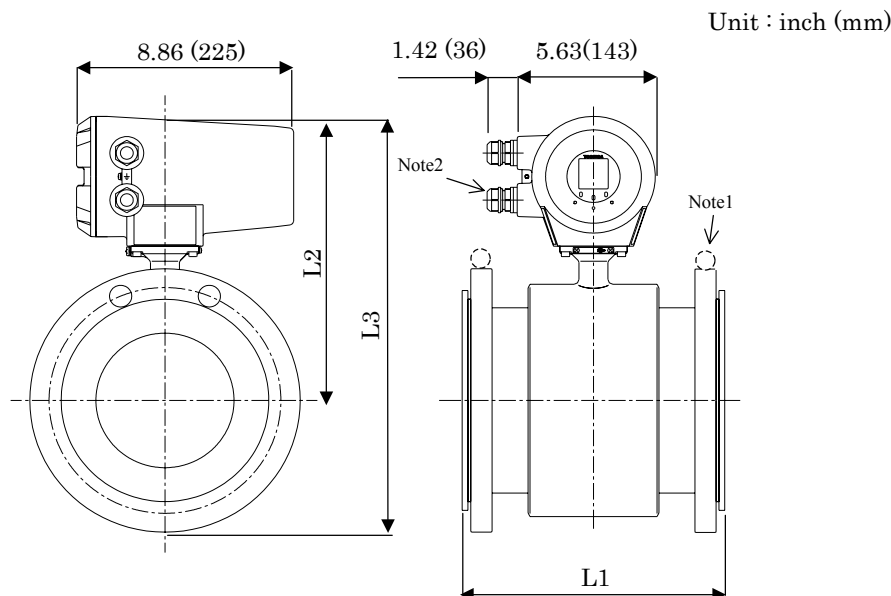

Note1: Eye bolts are provided at the top for flowmeters sized 8" (200mm) or above, and further, a roll-prevention base is provided for flowmeters sized 10" (250mm) or larger.

Note2: Cable glands are not provided for LF434 of cFMus approved type. Refer to the part Cable connection port at detector.

ANSI class 150 dimensions:

Meter size (inch)	L1 (inch)	L2 (inch)	L3 (inch)	No. of volts	Weight (lbs)
1/2	5.51	8.66	10.41	4	approx. 13
1	6.30	8.78	10.91	4	approx. 17
1-1/2	6.69	9.09	11.59	4	approx. 22
2	7.09	9.45	12.44	4	approx. 29
3	9.06	10.00	12.81	4	approx. 46
4	9.45	10.70	13.96	8	approx. 59
6	10.24	11.89	15.73	8	approx. 87
8	11.81	12.91	18.56	8	approx. 128
10	13.78	13.82	21.82	12	approx. 254
12	15.75	14.69	24.39	12	approx. 303
14	17.72	15.55	26.25	12	approx. 360
16	19.69	16.38	28.13	16	approx. 462
18	21.65	17.52	28.90	16	approx. 514

JIS 10K dimensions:

Meter size (mm)	L1 (mm)	L2 (mm)	L3 (mm)	No. of bolts	Weight (kg)
15	140	220	268	4	approx. 6.0
25	160	223	286	4	approx. 8.5
40	170	231	301	4	approx. 10.5
50	180	240	318	4	approx. 12.5
65 (*4)	200	249	336	4	approx. 17.0
80	230	254	347	8	approx. 17.5
100	240	272	377	8	approx. 21.5
150	260	302	442	8	approx. 37.0
200	300	328	493	12	approx. 50.0
250	350	351	551	12	approx. 106.0
300	400	378	601	16	approx. 114.0
350	450	395	640	16	approx. 131.0
400	500	416	696	16	approx. 174.0
450	550	445	755	20	approx. 200.0

BS16 and DIN PN16 dimensions:

Meter size (mm)	L1 (mm)	L2 (mm)	L3 (mm)	No. of bolts	Weight (kg)
15	140	220	268	4	approx. 6.0
25	160	223	286	4	approx. 8.0
40	170	231	301	4	approx. 10.0
50	180	240	318	4	approx. 12.0
80	230	254	347	8	approx. 18.0
100	240	272	377	8	approx. 22.0
150	260	302	442	8	approx. 37.0
200	300	328	493	12	approx. 50.0
250	350	351	551	12	approx. 106.0
300	400	378	601	12	approx. 114.0
350	450	395	640	16	approx. 131.0
400	500	416	696	16	approx. 174.0
450	550	445	755	20	approx. 200.0

Note 3 : 1 inch = 25.4 mm

Note 4 : JIS 10K flange only without any Ex-approvals.

**Figure 3. LF430/LF610 and LF434/LF610F combined type flowmeters
Meter Sizes 1/2" (15) to 18" (450mm)**

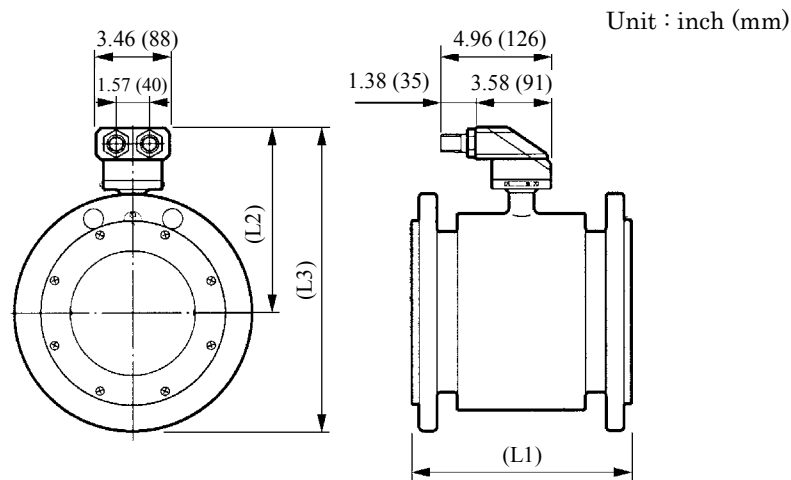

Unit : inch (mm)

Note1: Eye bolts are provided at the top for flowmeters sized 8" (200mm) or above, and further, a roll-prevention base is provided for flowmeters sized 10" (250mm) or larger.

Note2: Cable glands are not provided for LF434 of cFmus approved type. Refer to the part Cable connection port at detector.

ANSI class 150 dimensions:

Meter size (inch)	L1 (inch)	L2 (inch)	L3 (inch)	No. of volts	Weight (lbs)
1/2	5.51	5.79	7.56	4	approx. 9
1	6.30	5.87	7.99	4	approx. 13
1-1/2	6.69	6.22	8.74	4	approx. 18
2	7.09	6.57	9.57	4	approx. 24
3	9.06	7.13	10.87	4	approx. 40
4	9.45	7.83	12.36	8	approx. 52
6	10.24	9.02	14.53	8	approx. 81
8	11.81	10.03	16.81	8	approx. 120
10	13.78	10.94	18.94	12	approx. 249
12	15.75	12.01	21.54	12	approx. 298
14	17.72	12.68	23.19	12	approx. 355
16	19.69	13.50	25.28	16	approx. 459
18	21.65	14.63	27.13	16	approx. 510

JIS 10K dimensions:

Meter size (mm)	L1 (mm)	(L2) (mm)	L3 (mm)	No. of bolts	Weight (kg)
15	140	147	194	4	approx. 4.0
25	160	149	212	4	approx. 6.0
40	170	158	228	4	approx. 8.0
50	180	167	244	4	approx. 10.0
65 (*4)	200	176	263	4	approx. 15.0
80	230	181	274	8	approx. 16.0
100	240	199	304	8	approx. 20.0
150	260	229	369	8	approx. 35.0
200	300	255	420	12	approx. 48.0
250	350	278	478	12	approx. 106
300	400	305	528	16	approx. 116
350	450	322	567	16	approx. 141
400	500	343	623	16	approx. 176
450	550	372	682	20	approx. 200

BS16 and DIN PN16 dimensions:

Meter size (mm)	L1 (mm)	(L2) (mm)	L3 (mm)	No. of bolts	Weight (kg)
15	140	147	194	4	approx. 4.0
25	160	149	207	4	approx. 6.0
40	170	158	233	4	approx. 9.0
50	180	167	250	4	approx. 11.5
80	230	181	281	8	approx. 17.5
100	240	199	309	8	approx. 22.0
150	260	229	372	8	approx. 37.0
200	300	255	425	12	approx. 52.0
250	350	278	481	12	approx. 108
300	400	305	535	12	approx. 121
350	450	322	582	16	approx. 145
400	500	343	633	16	approx. 188
450	550	372	707	20	approx. 208

Note 3 : 1 inch = 25.4 mm

Note 4 : JIS 10K flange only without any Ex-approvals.

**Figure 4. Separate type detectors LF430 and LF434
Meter sizes 1/2" (15) to 18" (450mm)**

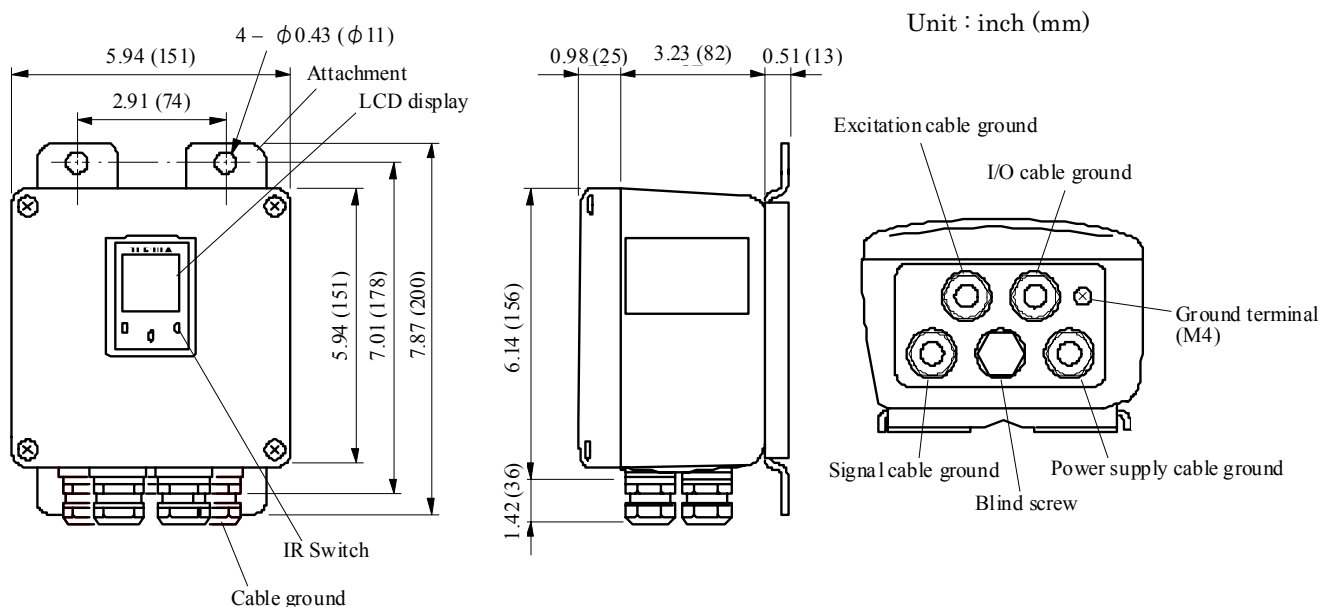
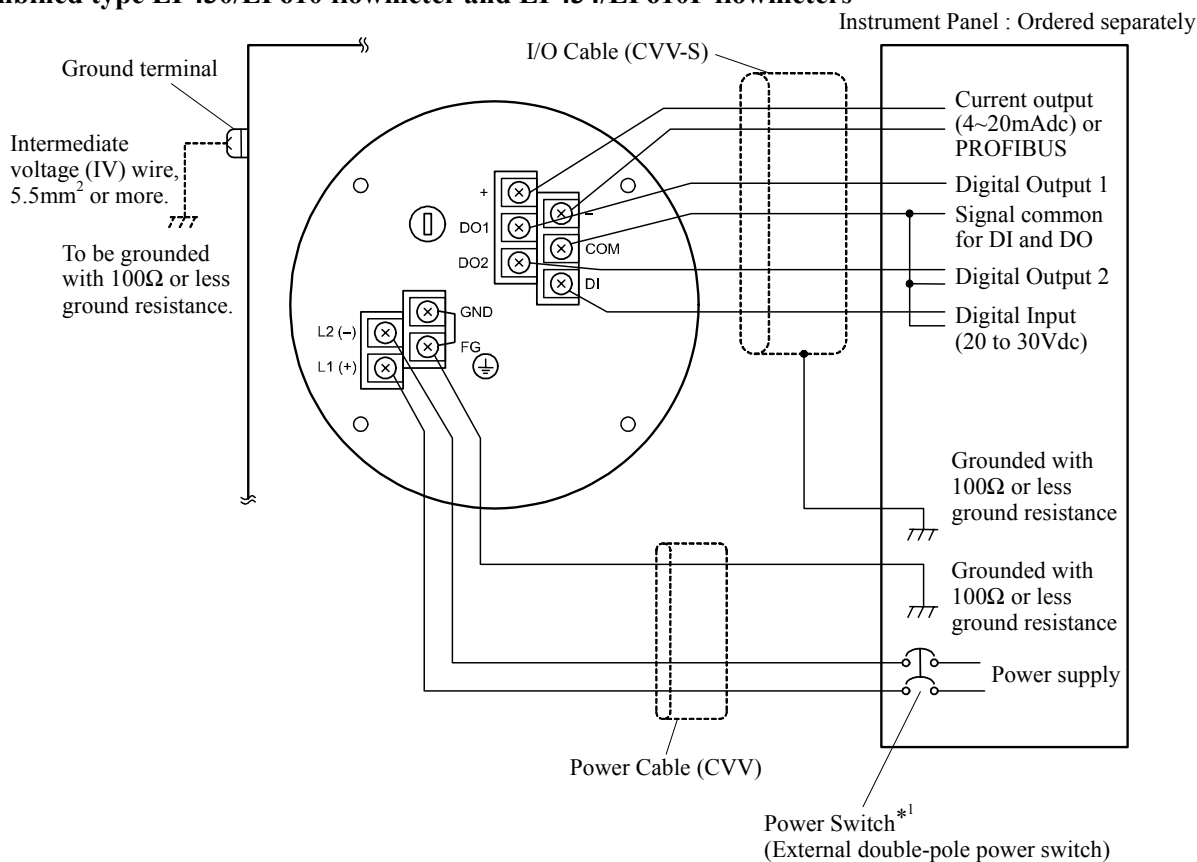

Figure 5. Separate type converter LF612 and LF612F

■ External Connections

- Combined type LF430/LF610 flowmeter and LF434/LF610F flowmeters



*1 Locate an external double-pole power switch on the power line near the flowmeter within easy reach of operation. Use the appropriate switch rating as shown below:
 Switch rating: 250Vac, 6A or more
 In rush current: 15A or more

Figure 6. Combined type LF430/LF610 and LF434/LF610F flowmeters Wiring Diagram

- Separate type LF430/LF612 flowmeter and LF434/LF612F flowmeters

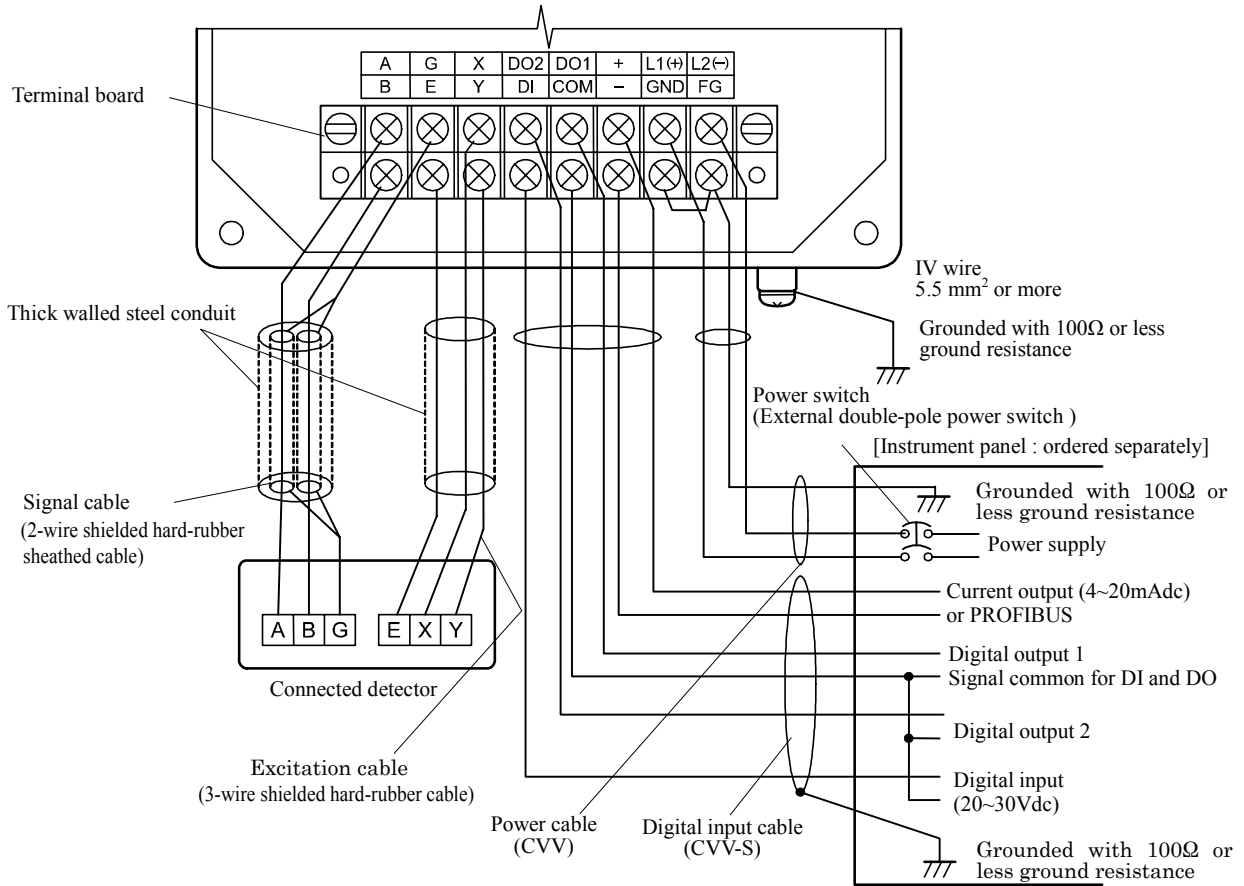

Figure 7. Separate type LF430/LF612 and LF434/LF612F flowmeters wiring Diagram

Table 2. LF610,LF610F, LF612 and LF612F Converters Signal Table

Symbol	Description	Cable
L1 (+)	Power supply	Power cable (CVV)
L2 (-)		
GND	Ground (for arrester)	
FG	Frame ground	
DI	Digital Input (20~30Vdc)	I/O cable (CVV-S)
DO1	Digital Output 1	
DO2	Digital Output 2	
COM	Signal Common for DI, DO1, DO2	
+	Current Output (4~20mAdc) or PROFIBUS	Shielded cable for PROFIBUS-PA
-		
X	Excitation Output	Excitation cable (for LF612,LF612F only)
Y		
E		
A	Signal Input	Signal cable (for LF612,LF612F only)
B		
G		

■ Wiring Precautions

- (1) Explosion proof type flowmeters are not provided cable glands.
Refer to the part Cable connection port at detector and converter.
- (2) Connect the grounding wire (IV wire 5.5mm² or more) to a good earth ground (100Ω or less ground resistance). Make the wire as short as possible. Do not use a common ground shared with other equipment where earth current may flow. An independent earth ground is recommended.
- (3) The allowable cable lengths between the detector and converter for the separate type flowmeter depend on the electrical conductivity of the object fluid. See Figure 8.
- (4) DO1, DO2 (opt.), and DI (opt.) use the same common terminal (COM). This COM can not connect to other equipments which have their own ground terminal. (Power supply for connecting to DI or DO, etc...) Need to wire separately.

■ Wiring Precautions (PROFIBUS)

- (1) For wiring path, avoid places near electrical equipment that may cause electromagnetic induction or electrostatic induction interference (such as a motor, transformer and wireless transmitter).
- (2) Use a PROFIBUS-PA cable for signal cable. In addition, make sure to use a shielded cable to improve noise resistance. Furthermore, installation of signal cable in metal conduit is recommended.
- (3) General PROFIBUS-PA cables are designed for indoor use where cables are not exposed to humidity, rain, etc. When you install cables, make sure to check the operating conditions such as the operating temperature range of the cable by contacting its manufacturer.
- (4) When you carry out cable end treatment of PROFIBUS-PA cable, use a dedicated cable stripper etc. so that the core wire of the cable will not be nicked or damaged. In addition, for cables, be careful of allowable maximum bend diameter etc. (Basically, do not install cables in a way cables are twisted or bent).
- (5) Consider installing a PROFIBUS-PA arrester in the communication path of PROFIBUS-PA so that the electromagnetic flowmeter will not be affected by lightning etc.
- (6) The electromagnetic flowmeter is not equipped with terminating resistors. Use the terminating resistor unit for PROFIBUS-PA or junction box,

if necessary.

- (7) Only one PROFIBUS-PA cable goes through a cable gland of the Electromagnetic Flowmeter. Please use the junction box at system configuration.

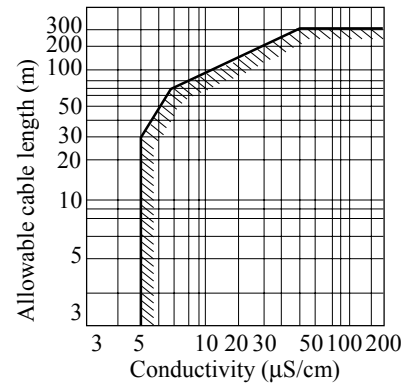

Figure 8. Electrical Conductivity and Cable Length

■ Meter Size

To select the meter size:

See Table 3 to 4 and find meter sizes within the velocity of 0.3 to 32.8 ft/s (0.1 to 10m/s) for a specified full-scale (measuring range high limit) flow. Select one that has its full-scale velocity between 3.0 and 10 ft/s (1 and 3m/s).

Note: Make sure the full-scale flow rate used for the final planning stage stays within 32.8ft/s (10m/s) in terms of flow velocity.

Table 3. Flow Rate and Flow velocity (English unit)

Unit: gal/min

Size (inch)	Flow rate				
	0.3ft/s	0.98ft/s	3ft/s	10ft/s	32.8ft/s
1/2	0.2801	0.8403	2.561	8.532	28.01
1	0.7781	2.334	7.115	23.72	77.81
1 1/2	1.992	5.975	18.21	60.71	199.2
2	3.112	9.337	28.46	94.86	311.2
3	7.967	23.90	72.85	242.8	796.7
4	12.45	37.35	113.8	379.4	1,245
6	28.01	84.03	256.1	853.8	2,801
8	49.80	149.4	455.3	1,518	4,980
10	77.81	233.4	711.5	2,372	7,781
12	112.0	336.1	1,025	3,415	11,200
14	152.5	457.5	1,394	4,648	15,250
16	199.2	597.5	1,821	6,071	19,920
18	252.1	756.3	2,305	7,684	25,210

Table 4. Flow Rate and Flow velocity (SI unit)Unit: m³/h

Size (mm)	Flow rate				
	0.1 m/s	0.3 m/s	1.0 m/s	3 m/s	10 m/s
15	0.0636	0.1908	0.6361	1.908	6.361
25	0.1767	0.5301	1.767	5.301	17.67
32 ^{*1}	0.2895	0.8686	2.895	8.686	28.95
40	0.4523	1.357	4.523	13.57	45.23
50	0.7067	2.120	7.067	21.20	70.67
65 ^{*1}	1.195	3.583	11.95	35.83	119.5
80	1.809	5.428	18.09	54.28	180.9
100	2.827	8.482	28.27	84.82	282.7
150	6.361	19.08	63.61	190.8	636.1
200	11.31	33.93	113.1	229.3	1,131
250	17.67	53.01	176.7	530.1	1,767
300	25.45	76.34	254.5	763.4	2,545
350	34.64	103.9	346.4	1,039	3,464
400	45.23	135.7	452.3	1,357	4,523
450	57.25	171.7	572.5	1,717	5,725

Note 1: JIS 10K flange type only.**■ About establishment environment**

Do not store or install the flowmeter :

- Where there is direct sunlight.
- Where excessive vibration or mechanical shock occurs.
- Where high temperature or high humidity conditions exist.
- Where corrosive atmospheres exist.
- Places that can be submerged under water.
- Where there is a sloped floor. To put the flowmeter temporarily on the floor, place it carefully with something, such as a block, to support it so that the flowmeter will not topple over.

In areas like the following, there may be the case that infrared switches do not function correctly. (If these are unavoidable, use an appropriate cover.)

- (1) Where unit (operation panel) is exposed to direct sunlight, reflection of light onto window pane and diffused light reflection.
- (2) Where smoke and steam may occur.
- (3) Where exposed to direct snow, ice or mud.

■ Calibration Range

If the calibration range is not specified, the standard range as shown below will be used. If the range is specified, we will use the specified range for calibration.

Table 5. Standard Flow Range

Meter size inch(mm)	Standard flow range		
	Flow rate (gal/min)	Flow rate (m ³ /h)	Flow velocity (m/s)
1/2 (15)	25	2	3.144
1 (25)	75	6	3.395
1 1/4 (32)	125	10	3.454
1 1/2 (40)	175	15	3.316
2 (50)	300	25	3.537
2 1/2 (65)	475	40	3.348
3 (80)	650	60	3.316
4 (100)	1,000	100	3.537
6 (150)	2,500	200	3.144
8 (200)	4,500	300	2.653
10 (250)	7,000	600	3.395
12 (300)	10,000	900	3.537
14 (350)	12,000	1,200	3.465
16 (400)	16,000	1,600	3.537
18 (450)	20,000	2,500	4.366

Note: The unit of "gal/min" is not exchanged (converted) by "m³/h".

Ordering Information

1. When ordering the LF430 series flowmeters, refer to Tables 6 and 7 (Type Specification Codes). An entry must be made for each of the columns in each of these tables.
2. Fluid characteristics:
 - (1) Type of fluid to be measured and its characteristics
 - (2) Fluid temperature
 - (3) Fluid pressure
 - (4) Electrical conductivity of the fluid
3. Measuring range
4. I/O function setting
5. Ordering scope:
 - Flow calibration data: (required or not)
6. Other items
 - Specifications other than standard items

Consult a Toshiba representative before ordering when choosing materials of the wetted parts such as lining, electrodes, and grounding rings.

Table 6. Specification Code (Flange type detector LF430 Series)

Model					Specification Code									Description	Detector category				
1	2	3	4	5	6	7	8	9	10	11	12	13	14		Normal type		Ex. type		
															Gr.-A	Gr.-B	Gr.-C	Gr.-D	
L	F	4	3	0											Normal specification type	√	√		
L	F	4	3	4											Hazardous location certification type (Note 1)			√	√
					D										Meter size				
					E										½"(15mm)	√		√	
					S										1"(25mm)	√		√	
					F										1¼"(32mm) (Note 7)	√		—	
					G										1½"(40mm)	√		√	
					W										2"(50mm)	√		√	
					H										2½"(65mm) (Note 7)	√		—	
					J										3"(80mm)		√		√
					K										4"(100mm)		√		√
					L										6"(150mm)		√		√
					M										8"(200mm)		√		√
					N										10"(250mm)		√		√
					P										12"(300mm)		√		√
					Q										14"(350mm)		√		√
					R										16"(400mm)		√		√
															18"(450mm)		√		√
					L										Mounting Style				
					M										Detector/Converter combined type (LF430/LF610)	√	√		
					P										Detector/Converter separate type (LF430/LF612)	√	√		
					Q										Detector/Converter combined type with PED (LF430/LF610) (Note 6)	√	√		
					A										Detector/Converter separate type with PED (LF430/LF612) (Note 6)	√	√		
					B										cFMus Class I - Division 2 type (Note 1)				
															Detector/Converter combined type (LF434/LF610F)			√	√
															Detector/Converter separate type (LF434/LF612F)			√	√
					C										Connection flange standard				
					D										ANSI 150	●	●	●	●
					E										ANSI 300	○	○	○	○
					F										BS PN 10	○	○	○	○
					G										BS PN 16	○	○	○	○
					H										DIN PN 10	●	●	●	●
					J										DIN PN 16	●	●	●	●
					K										JIS 10K	●	●	●	●
					L										JIS 16K	○	○	○	○
					Z										JIS 20K	○	○	○	○
															Other	○	○	—	—
					B										Electrode Material (Note 5)				
					C										316L stainless steel	●	●	○	●
					D										Ti (titanium)	○	○	○	○
					E										Pt-Ir (platinum/iridium)	○	○	○	○
					F										Ta (tantalum)	○	○	○	○
					Z										Hastelloy C (Equivalent)	○	○	●	○
															Other	○	○	—	—
					C										Lining Materials (Note 5)				
					D										Teflon FPA	●	○	●	○
															EPDM rubber	—	●	—	●
					C										Grounding Ring Material (Note 5)				
					D										316 stainless steel	●	●	●	●
					E										316L stainless steel	○	○	○	○
					F										Ti (titanium)	○	○	○	○
					G										Ta (tantalum)	—	—	—	—
					H										Pt-Ir (platinum/iridium)	—	—	—	—
					Z										Hastelloy C (Equivalent)	○	○	○	○
															Other	○	○	—	—
					A										Flow and calibration velocity range				
					B										1.0 to 32.8 ft/s (standard range calibration)	●	●	●	●
					C										1.0 to 32.8 ft/s (specified range calibration)	○	○	○	○
															0.3 to 32.8 ft/s (specified range calibration)	○	○	○	○
					A										Excitation and Signal Cables				
					B										not provided	●	●	●	●
					C										30m cable, provided (Note 2)	○	○	○	○
															other lengths, provided (Note 3)	○	○	○	○
					B										Coating				
					C										phthalic acid resin coating pearl-gray colored	●	●	●	●
					D										black tar epoxy resin 0.3mm	○	○	○	○
					E										black tar epoxy resin 0.5mm	○	○	○	○
															black tar epoxy resin 0.5mm for submersible type (Note 4)	—	○	—	○

Size code explanation: √: Object ●: Standard ○: Option —: Not available

Note1: Cable glands are not provided. Refer to the part of "Cable connection port" at detector and converter.

Note2: Separate type detector only.

Note3: Separate type detector only. Specifying the code "C", indicate the length of cables from 1 to 300m 1 meter increments.

Note4: EPDM rubber lining is available to choose only in this specification.

Note5: Consult Toshiba before ordering when choose materials at the wetting parts.

Note6: Check the Table 1 whether your chosen meter size meets this directive or not when the meter is shipped to EU. If yes, need to choose this code.

Note7: JIS 10K flange only without any Ex-approvals.

Table 7. Specification Code for converters

Model				Specification Code										Contents	LF610 type	LF612 type	
1	2	3	4	5	6	7	8	9	10	11	12	13	14				
L	F	6	1												Electromagnetic flowmeter converter		
				0											Combined (Integral) type	●	—
				2											Separate (Remote) type	—	●
					A										Purpose		
					F										Standard	●	●
															cFMus class I, Division 2 approved	○	○
						A									Shape		
						B									Integral type with case	●	—
															Separate type with case	—	●
							A								Converter mounting fitting		
							C								None	●	○
							E								Panel, Accessory for wall mounting (BNP material: SUS304)	—	●
															Accessory for pipe installation (BNP material: SUS304)	—	○
								1							Digital input/output		
								2							Digital output points 1 (DO1)	●	●
															Digital output points 2 (DO1+DO2) +Digital input point 1 (DI)	○	○
									1						Current output and Communication function		
									2						Current output + HART communication	●	●
															PROFIBUS communication (Current output is not usable)	○	○
										1					Power supply		
										2					100Vac-240Vac, 50/60Hz	●	●
										3					24Vdc	○	○
															110Vdc	○	○
											E				Instruction manual		
															English	●	●

Code explanation: ●: Standard ○: Option —: Not available

ISO9001 and ISO14001 are certified.

Specifications are subject to change without notice.

Printed in Japan 2008-5(TDOC)

© TOSHIBA Corporation 2008

All Rights Reserved.

<http://www.toshiba.com/ind/>

